

Manual

Planetary Ball Mill PM100 / PM200

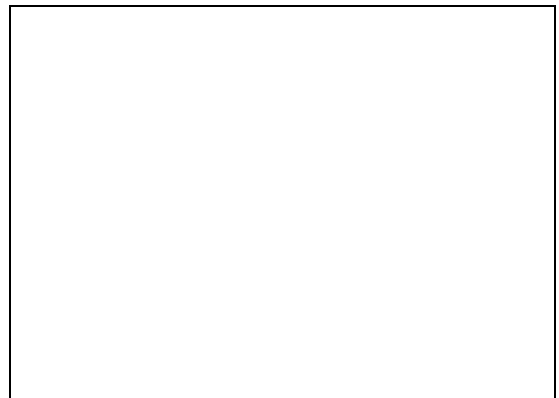

Translation

Retsch[®]

Copyright

© Copyright by
Retsch GmbH
Retsch-Allee 1-5
42781 Haan
Germany

Table of Contents

1	Notes on the Manual	7
1.1	Explanations of the Safety Instructions	8
1.2	General Safety Instructions	9
1.3	Repairs	10
2	Confirmation	11
3	Packaging, Transport and Installation	12
3.1	Packaging	12
3.2	Transport	12
3.3	Temperature fluctuations and condensed water	12
3.4	Conditions for the Installation Site	13
3.5	Installation of the Device	13
3.6	Type Plate Description	13
3.7	Electrical Connection	14
3.8	Creating interface connection	15
3.9	Transport	15
3.10	Installation of the Device	18
4	Technical Data	19
4.1	Use of the Device for the Intended Purpose	19
4.2	Number of grinding stations	20
4.3	Receptacle Volume	20
4.4	Feed Grain Size	20
4.5	Rated Power	20
4.6	Electrical Connection	20
4.7	Emissions	21
4.7.1	Noise levels PM 100	21
4.7.2	Noise levels PM 200	21
4.8	Degree of Protection	21
4.9	Protective Equipment	22
4.10	Dimensions and Weight	22
4.11	Required Floor Space	22
5	Operating the Device	23
5.1	Views of the Instrument	23
5.2	Overview table of the parts of the device	26
5.3	Operating elements and displays	27
5.4	Overview Table of the Operating Elements and the Display	27
5.5	Opening the device	27
5.6	Closing the device	28
5.7	Emergency Unlocking	28
5.8	Inserting the Grinding Jar	30
5.8.1	Inserting the grinding jar	31
5.8.2	Inserting the clamping unit	32
5.8.3	Function of the locking sleeve	32
5.9	Balancing the device – only for the PM 100	33
5.10	Balancing the device with additional weight – only for PM 100	34
5.10.1	Combination 1:	34
5.10.2	Combination 2:	34
5.10.3	Combination 3:	34
5.11	Releasing the grinding jar clamping mechanism	35
5.12	Opening the Clamping Mechanism with the Opening Aid for the Clamping Unit	36
5.13	Power failure during grinding	37
5.14	Grinding Jar Selection for Different Sample Materials	37
5.15	Sample quantity	38
5.15.1	Guides for material quantity and balls	38
5.16	Ultrafine grinding	38

5.17	Stacking the grinding jars	39
5.17.1	Stacking the 50 ml and 80 ml grinding jars.....	39
5.17.2	Stacking the 25 ml and 12 ml grinding jars.....	40
5.18	Handling grinding jars	40
5.18.1	Carrying and gripping	41
5.18.2	Anti-rotation device	41
5.18.3	Heating the grinding jars.....	41
5.19	Grinding jar identification	42
5.19.1	Customer labelling on the grinding jar	42
5.20	Grinding jar cleaning.....	43
5.20.1	Drying the grinding jars.....	43
5.21	Opening and closing of the grinding jars with safety locking device	44
5.22	Wet Grinding with Highly Flammable Materials.....	46
6	Display and operation.....	47
6.1	Symbols in the Display Unit	47
6.2	Display unit – operation of the device	47
6.2.1	Adjustment options using the display menu	48
6.2.2	Navigating between operating modes	48
6.3	Direct access to the language menu.....	48
6.4	Menu structure	50
6.5	Operating modes.....	50
6.5.1	Manual operation	50
6.5.2	Program 01 to 10.....	50
6.5.3	Basic settings.....	51
6.6	Manual Mode.....	51
6.6.1	Grinding time.....	51
6.6.2	Speed.....	51
6.6.3	Interval	51
6.6.4	Direction reversal.....	51
6.6.5	Pause time	51
6.6.6	Save parameters	52
6.6.7	Start in.....	52
6.7	Programme Mode.....	52
6.7.1	Change program	52
6.7.2	Delete program	52
6.8	Basic settings	53
6.8.1	Automatic opening	53
6.8.2	Language.....	53
6.8.3	Brightness.....	53
6.8.4	Date	53
6.8.5	Time	53
6.8.6	Acoustic warning signal	53
6.8.7	Service	53
6.8.7.1	Operating hours	53
6.8.7.2	Software version of display.....	53
6.8.7.3	Software version of the controller	54
6.8.7.4	Update software.....	54
6.8.7.4.1	Safety notice	54
7	Fault messages.....	55
8	Installing additional equipment	56
8.1	Adapter for glass vials.....	56
8.1.1	Speed limits	58
8.1.2	Energy input.....	58

9	Cleaning, Wear and Maintenance	59
9.1	Maintenance	59
9.1.1	Servicing the closing pin	59
9.1.2	Servicing the clamping unit	60
9.1.3	Rubber washer on the pressure plate	61
9.1.4	Wear to latching bracket	61
9.2	Return for Service and Maintenance	62
10	Disposal	63
11	Index	64

1 Notes on the Manual

This operating manual is a technical guide on how to operate the device safely and it contains all the information required for the areas specified in the table of contents. This technical documentation is a reference and instruction manual. The individual chapters are complete in themselves.

Familiarity (of the respective target groups defined according to area) with the relevant chapters is a precondition for the safe and appropriate use of the device.

This operating manual does not contain any repair instructions. If faults arise or repairs are necessary, please contact your supplier or get in touch with Retsch GmbH directly.

Application technology information relating to samples to be processed is not included but can be read on the Internet on the respective device's page at www.retsch.com.

Changes

Subject to technical changes.

Copyright

Disclosure or reproduction of this documentation, use and disclosure of its contents are only permitted with the express permission of Retsch GmbH.

Infringements will result in damage compensation liability.

1.1 Explanations of the Safety Instructions

In this Operating Manual we give you the following safety warnings

Serious injury may result from failing to heed these safety warnings. We give you the following warnings and corresponding content.

 **WARNING**

Type of danger / personal injury

Source of danger

- Possible consequences if the dangers are not observed.
 - **Instructions on how the dangers are to be avoided.**
-

We also use the following signal word box in the text or in the instructions on action to be taken:

 **WARNING**

Moderate or mild injury may result from failing to heed these safety warnings. We give you the following warnings and corresponding content.

 **CAUTION**

Type of danger / personal injury

Source of danger

- Possible consequences if the dangers are not observed.
 - **Instructions on how the dangers are to be avoided.**
-

We also use the following signal word box in the text or in the instructions on action to be taken:

 **CAUTION**

In the event of possible **property damage** we inform you with the word “Instructions” and the corresponding content.

NOTICE

Nature of the property damage

Source of property damage

- Possible consequences if the instructions are not observed.
 - **Instructions on how the dangers are to be avoided.**
-

We also use the following signal word in the text or in the instructions on action to be taken:

NOTICE

1.2 General Safety Instructions

CAUTION

Read the Operating Manual

Non-observance of these operating instructions

- The non-observance of these operating instructions can result in personal injuries.
- **Read the operating manual before using the device.**
- **We use the adjacent symbol to draw attention to the necessity of knowing the contents of this operating manual.**



Target group : All persons concerned with the machine in any form

This machine is a modern, high performance product from Retsch GmbH and complies with the state of the art. Operational safety is given if the machine is handled for the intended purpose and attention is given to this technical documentation.

You, as the owner/managing operator of the machine, must ensure that the people entrusted with working on the machine:

- have noted and understood all the regulations regarding safety,
- are familiar before starting work with all the operating instructions and specifications for the target group relevant for them,
- have easy access always to the technical documentation for this machine,
- and that new personnel before starting work on the machine are familiarised with the safe handling of the machine and its use for its intended purpose, either by verbal instructions from a competent person and/or by means of this technical documentation.

Improper operation can result in personal injuries and material damage. You are responsible for your own safety and that of your employees.

Make sure that no unauthorised person has access to the machine.

CAUTION

Changes to the machine

- Changes to the machine may lead to personal injury.
- **Do not make any change to the machine and use spare parts and accessories that have been approved by Retsch exclusively.**

NOTICE

Changes to the machine

- The conformity declared by Retsch with the European Directives will lose its validity.
- You lose all warranty claims.
- **Do not make any change to the machine and use spare parts and accessories that have been approved by Retsch exclusively.**

2 Confirmation

This operating manual contains essential instructions for operating and maintaining the device which must be strictly observed. It is essential that they be read by the operator and by the qualified staff responsible for the device before the device is commissioned. This operating manual must be available and accessible at the place of use at all times.

The user of the device herewith confirms to the managing operator (owner) that (s)he has received sufficient instructions about the operation and maintenance of the system. The user has received the operating manual, has read and taken note of its contents and consequently has all the information required for safe operation and is sufficiently familiar with the device. As the owner/managing operator you should for your own protection have your employees confirm that they have received the instructions about the operation of the machine.

I have read and taken note of the contents of all chapters in this operating manual as well as all safety instructions and warnings.

User

Surname, first name (block letters)

Position in the company

Signature

Service technician or operator

Surname, first name (block letters)

Position in the company

Place, date and signature

3 Packaging, Transport and Installation

3.1 Packaging

The packaging has been adapted to the mode of transport. It complies with the generally applicable packaging guidelines.

NOTICE

Storage of packaging

- In the event of a complaint or return, your warranty claims may be endangered if the packaging is inadequate or the machine has not been secured correctly.
 - **Please keep the packaging for the duration of the warranty period.**
-

3.2 Transport

NOTICE

Transport

- Mechanical or electronic components may be damaged.
 - **The machine may not be knocked, shaken or thrown during transport.**
-

NOTICE

H0014

Complaints

- The forwarding agent and Retsch GmbH must be notified immediately in the event of transport damage. It is otherwise possible that subsequent complaints will not be recognised.
 - **Notify your forwarding agent and Retsch GmbH within 24h**
-

3.3 Temperature fluctuations and condensed water

NOTICE

Temperature fluctuations

The machine may be subject to strong temperature fluctuations during transport (e.g. aircraft transport)

- The resultant condensed water may damage electronic components.
 - **Protect the machine from condensed water.**
-

3.4 Conditions for the Installation Site

Ambient temperature: 5°C to 40°C

NOTICE

Ambient temperature

- Electronic and mechanical components may be damaged and the performance data alter to an unknown extent.
- **Do not exceed or fall below the permitted temperature range of the machine (5°C to 40°C / ambient temperature).**

3.5 Installation of the Device

Installation height: maximum 2000 m above sea level

3.6 Type Plate Description

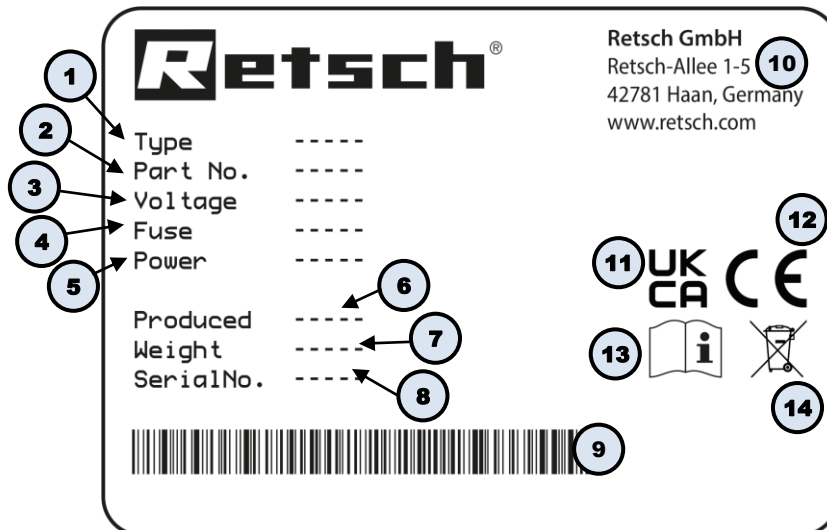

Fig. 1: Type plate

- 1 Device designation
- 2 Part number
- 3 Power version, Mains frequency
- 4 Fuse type and fuse strength
- 5 Capacity, Amperage
- 6 Year of production
- 7 Weight
- 8 Serial number
- 9 Bar code
- 10 Manufacturer's address
- 11 UKCA marking
- 12 CE marking
- 13 Safety warning: Read the manual
- 14 Disposal label

- ① In the case of queries please provide the device designation (1) or part number (2), as well as the serial number (8) of the device.

3.7 Electrical Connection

 **WARNING**

When connecting the power cable to the mains supply, use an external fuse that complies with the regulations applicable to the place of installation .

- Please check the type plate for details on the necessary voltage and frequency for the device.
- Make sure the levels agree with the existing mains power supply.
- Use the supplied connection cable to connect the device to the mains power supply.
- Make sure that the voltage and frequency of your mains connection corresponds to that on the type plate.
- The mains connection must be fused to at least 16A.
- An electrical connection without protective earth PE is not permitted.

The drive of the device is equipped with a frequency converter. In order to satisfy the EMC Directive, this is fitted with a mains filter and shielded cables to the motor. If your mains connection includes a residual current protection device, the suppressor capacitor wiring of the frequency converter when this is switched on (it is switched on by closing the grinding chamber hood) can lead to accidental triggering of the residual current protection device without any error being present on the device or in the mains installation.

In accordance with the state of the art, selective all current sensitive residual current protection devices are recommended for such cases. The tripping current must be sufficiently dimensioned because capacitive compensating current (shielded cable, mains filter) which only occurs for a short time can easily lead to accidental triggering.

In certain circumstances, it may be necessary to operate the device without a residual current protection device. It is then necessary, however, to check that this does not contravene the local regulations of the electricity company or other institutions and the applicable standards.

3.8 Creating interface connection

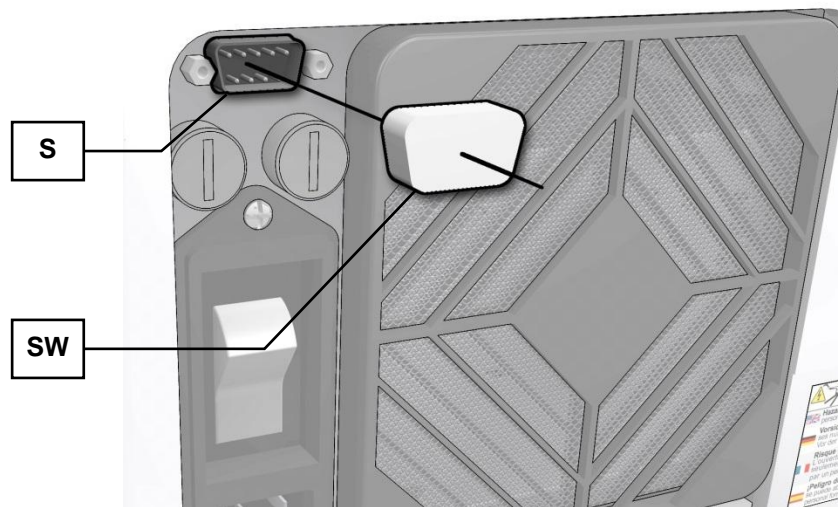

Fig. 2: Serial interface

- When updating the device control or display software, a connection with the PC is established using the RS232 interface (**S**).
- Leave the cap (**SW**) on the interface (**S**) when the connection is not needed.

NOTICE

The interface cables must not be longer than 2.5m. Longer cables can lead to faults in data transmission.

3.9 Transport

 **WARNING**

Serious personal injury

Falling loads

- The appliance is very heavy and can therefore cause serious personal injuries if it falls down.
- **Lifting above head height is not permissible!**

NOTICE

Transport

- Mechanical or electronic components may be damaged.
- **The machine may not be knocked, shaken or thrown during transport.**

NOTICE

N1.0018

Transportation lock

Transport without transportation lock, or operation with transportation lock

- Mechanical components may be damaged.
- **Only transport the device with mounted transportation lock.**
- **Do not operate the device with built-in transportation lock.**

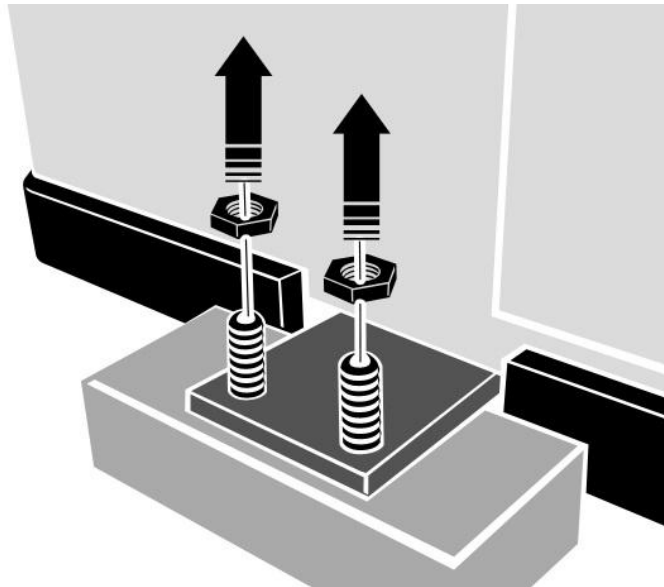

Fig. 3: Unscrewing the transport lock from the transport pallet

NOTICE

Only transport on the transport pallet using a forklift or pallet truck. The device is secured to the transport pallet by the transport lock and four nuts

- Use a 13mm spanner to unscrew the four nuts.

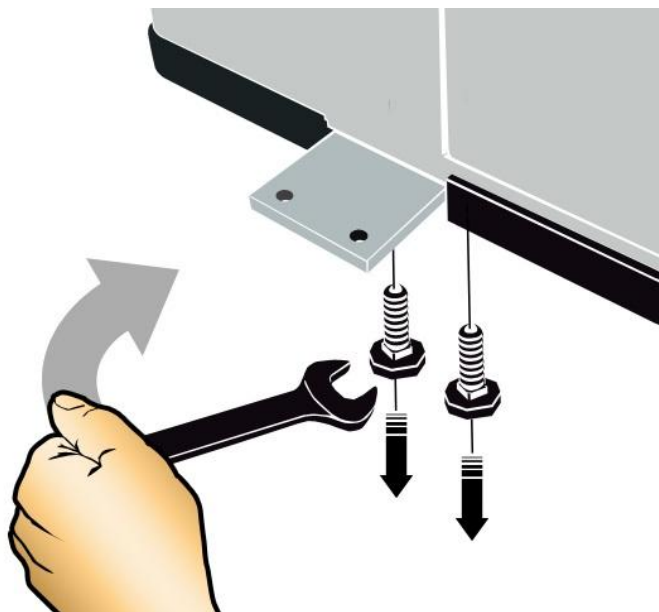

Fig. 4: Removing the transport lock from the device

Four bolts secure the transport lock to the underneath of the device.

- Use a 13mm spanner to unscrew the four bolts.

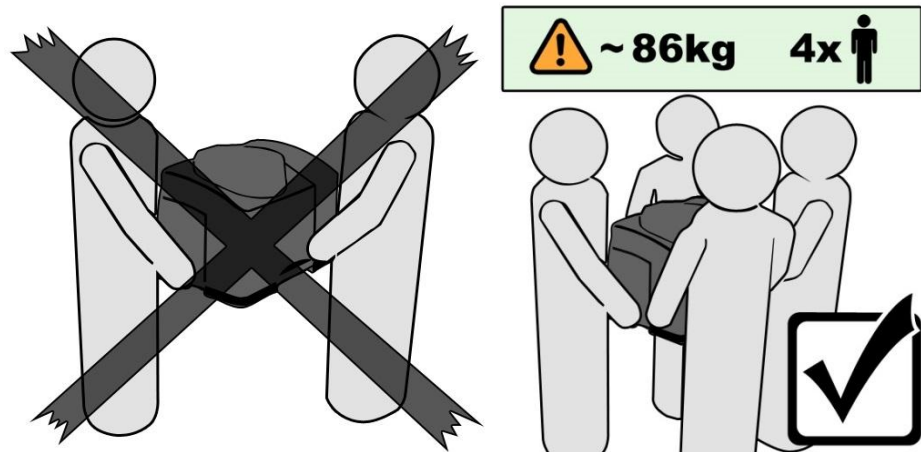

Fig. 5: Carrying the device

The device should be carried by four people.

Net weight PM 100 approx. 86 kg

Net weight PM 200 approx. 80 kg

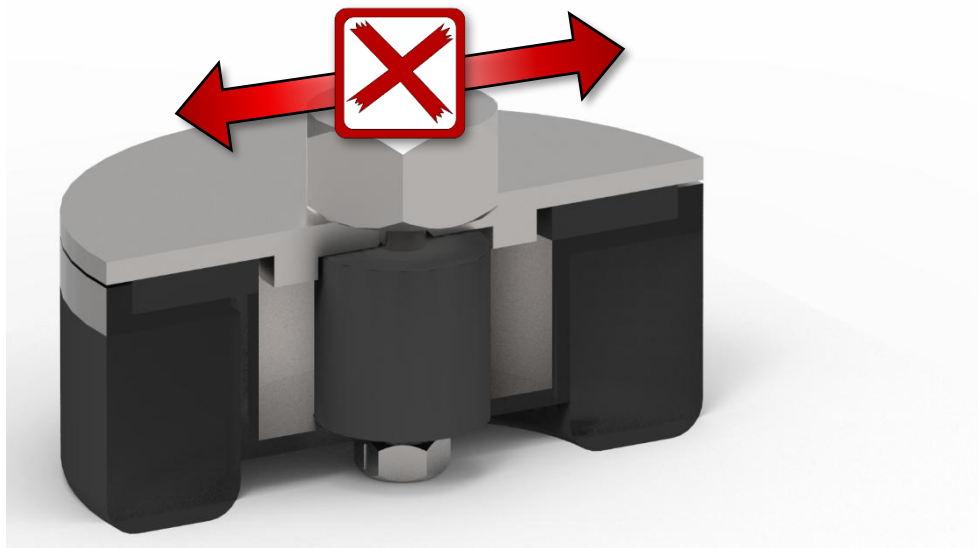

Fig. 6: Free-force compensation sockets: do not push or pull the device

NOTICE

N2.0071

Damage to the free-force compensation sockets

Pushing or pulling the device

- The free-force compensation sockets will be damaged if the device is pulled or pushed across a surface.
- **Do not pull or push the device.**
- **Lift the device to move it.**

3.10 Installation of the Device

Installation height: maximum 2000 m above sea level

**CAUTION****Device falling down**

Incorrect assembly or unsuitable workplace

- The appliance is very heavy and can therefore cause serious personal injuries if it falls down.

- **Operate the device only on a sufficiently large, firm, skid-resistant and steady workplace.**
 - **Make sure that all equipment feet are steady.**
-

NOTICE

Installation of the machine

- It must be possible to disconnect the machine from the mains at any time.
 - **Install the machine such that the connection for the mains cable is easily accessible.**
-

4 Technical Data

4.1 Use of the Device for the Intended Purpose



1.V0004

Risk of explosion or fire

Changing sample properties

- Consider that the properties and therefore also the hazardousness of your sample can change during the grinding process.
- **Do not use any substances in this device which carry the risk of explosion or fire.**



Risk of explosion or fire

- On account of its design, the device is not suitable for use in hazardous (potentially explosive) atmospheres.

- **Do not operate the device in a hazardous atmosphere.**



Danger of personal injury

Dangerous nature of the sample

- Depending on the dangerous nature of your sample, take the necessary measures to rule out any danger to persons.
- **Observe the safety guidelines and datasheets of your sample material.**



Target group: Operating companies, operators

Machine type designation: PM 100 / PM 200

Retsch ball mills are used to grind and mix soft, medium hard and extremely hard, brittle and fibrous materials. Dry and wet grinding are possible. Grinding with solvents is permitted, however in this case it is vital to note the supplementary information in the chapter “Wet grinding with highly flammable materials”. Minerals, ores, alloys, chemicals, glass, ceramics, parts of plants, soil, sewage sludge, house or industrial waste and many other substances can be ground simply, quickly and without loss. The ball mills are used successfully in almost all areas of industry and research. This applies in particular where there are high demands in terms of hygiene, speed, fineness and reproducibility.

Only grinding jars in Comfort design (discontinued summer 2023) and EasyFit design are compatible with the device.

PM 100: Grinding jars in the sizes 12 ml, 25 ml, 50 ml, 80 ml, 125 ml, 250 ml and 500 ml can be used. Stacking of grinding jars is possible in the sizes 12 ml, 25 ml, 50 ml and 80 ml.

PM 200: Grinding jars in the sizes 12 ml, 25 ml, 50 ml, 80 ml and 125 ml can be used. Stacking of grinding jars is possible in the sizes 12 ml and 25 ml.

In order to insert and stack specific grinding jars, you may need the adapters which are available as accessories.

NOTICE

Area of use of the machine

- This machine is a laboratory machine designed for 8-hour single-shift operation.
 - **This machine may not be used as a production machine nor is it intended for continuous operation.**
-

4.2 Number of grinding stations

1 grinding station PM 100

2 grinding stations PM 200

The grinding stations must be operated with the identical grinding jars and with the same weight during each grinding process.

NOTICE

H00681

Strong vibration and loud noise

Uneven load

- The device can produce very high levels of vibrations and noise when loading is uneven.
 - **Always use 2 grinding jars opposite each other.**
 - **The grinding stations must be operated with the identical grinding jars and with the same weight during each grinding process.**
 - **Switch the device off immediately if there are high levels of vibration and noise, and check the number and gross weight of the jars.**
-

4.3 Receptacle Volume

PM 100 = up to 300ml, depending on the grinding jar volume.

PM 200 = up to 2x50ml, depending on the grinding jar volume.

4.4 Feed Grain Size

PM 100 up to <10 mm, however this depends on the material

PM 200 up to <4 mm, however this depends on the material

4.5 Rated Power

750 W / Power consumption approx. 1250 W

Make sure that the voltage and frequency of your mains connection correspond to that on the type plate of the device. The mains connection must be fused to at least 16A.

4.6 Electrical Connection

WARNING

When connecting the power cable to the mains supply, use an external fuse that complies with the regulations applicable to the place of installation .

- Please check the type plate for details on the necessary voltage and frequency for the device.
- Make sure the levels agree with the existing mains power supply.
- Use the supplied connection cable to connect the device to the mains power supply.

The drive for the appliance is equipped with a frequency converter. To fulfil the EMC directive, this is equipped with a mains filter and shielded cables to the drive. If your mains connection for the device includes a residual current device, the fault protection circuit on the frequency inverter may cause the residual current device to trip incorrectly when it is switched on without there being a fault in the device or in the mains installation.

According to the current state of the art, selective, all-current sensitive residual current devices of type B or B+ are recommended in such cases. The tripping current must be sufficiently dimensioned, as capacitive equalising currents that occur only briefly can easily lead to false tripping when switching the unit on.

4.7 Emissions



Damage to hearing

The level of noise can be high depending on the type of material, the knife used, the speed set and the duration of the grinding process.

- Noise that is excessive in terms of level and duration can cause impaired or permanently damaged hearing.
- **Ensure suitable sound-proofing measures or wear hearing protection.**



4.7.1 Noise levels PM 100

Noise measurement in accordance with DIN 45635-31-01-KL3

The noise levels are largely influenced by the machine speed, the grinding jar size and the diameter of the grinding balls used.

Workplace-related equivalent sound pressure level $L_{ep} (L_{Im}) = 83 \text{ dB (A)}$ Measurement conditions PM 100

Grinding set: 1x 500ml special steel with 5 balls each Ø30mm TC (tungsten carbide)

Sample material: quartz, 135g each

Speed: 380 min⁻¹

4.7.2 Noise levels PM 200

Noise measurement in accordance with DIN 45635-31-01-KL3

The noise levels are largely influenced by the machine speed, the grinding jar size and the diameter of the grinding balls used.

Workplace-related emission equivalent sound pressure level $L_{ep} (L_{Im}) = 80 \text{ dB (A)}$

Measurement conditions PM 200

Grinding set: 2x 250ml special steel with 5 balls each Ø30mm TC

Sample material: quartz, 135g each

Speed: 380 min⁻¹.

4.8 Degree of Protection

IP20

4.9 Protective Equipment

This device is equipped with automatic lid closing which prevents it being started in an unsafe state.

- The device can only be started with closed lid.
- The lid can only be opened when the device has come to a halt.

4.10 Dimensions and Weight

Height: up to approx. 480 (780) mm / Width: 640 mm / Depth: up to approx. 420 mm

Weight:

PM 100 net approx. 82 kg (200-230 V), approx. 88 kg (100-120 V)

PM 200 net approx. 73 kg (200-230 V), approx. 79 kg (100-120 V)

4.11 Required Floor Space

630mm x 505mm;

NOTICE

A clearance distance of 200mm is necessary at the back to allow the fans to operate.

5 Operating the Device

5.1 Views of the Instrument

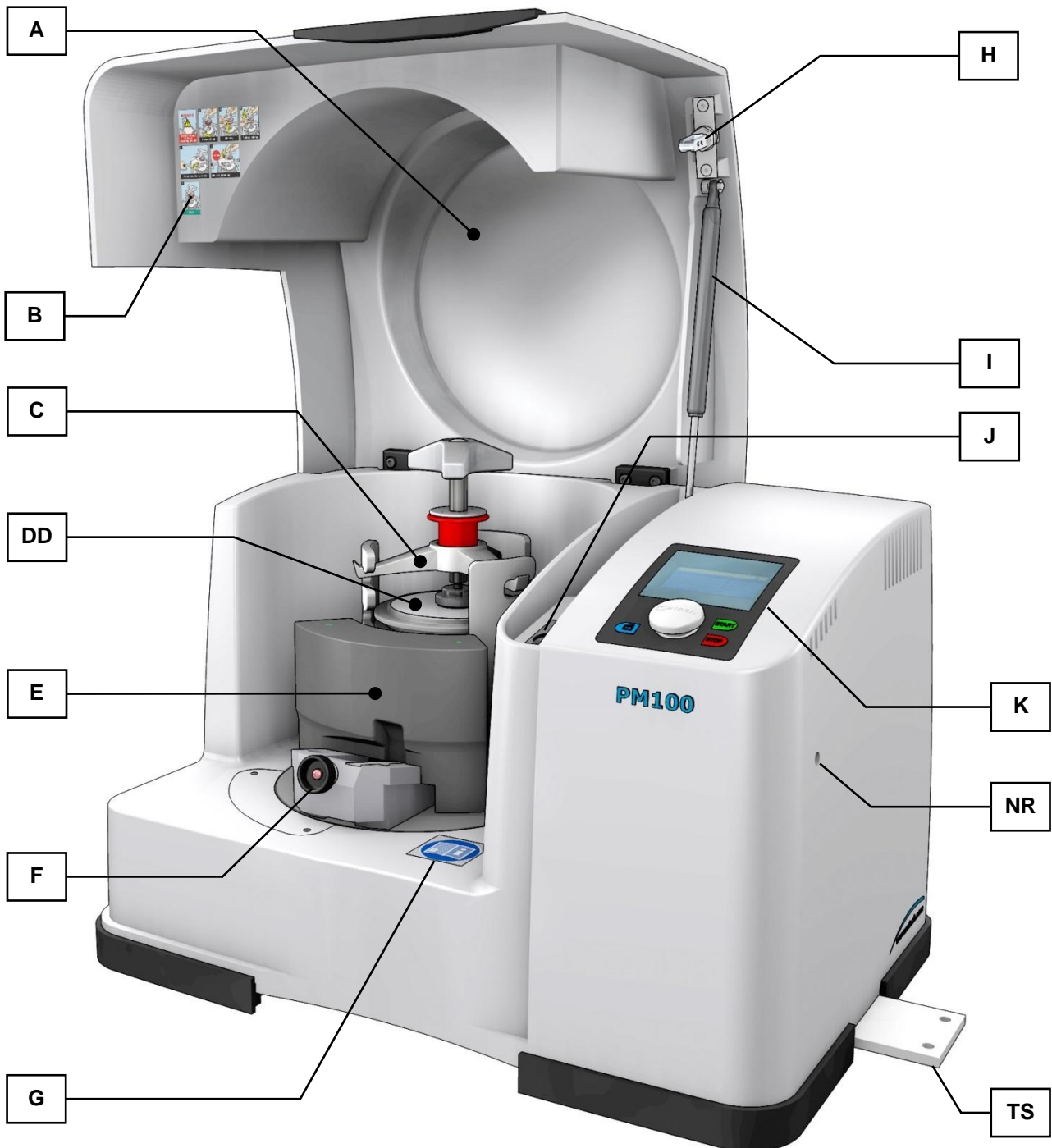

Fig. 7: View of the front of the device

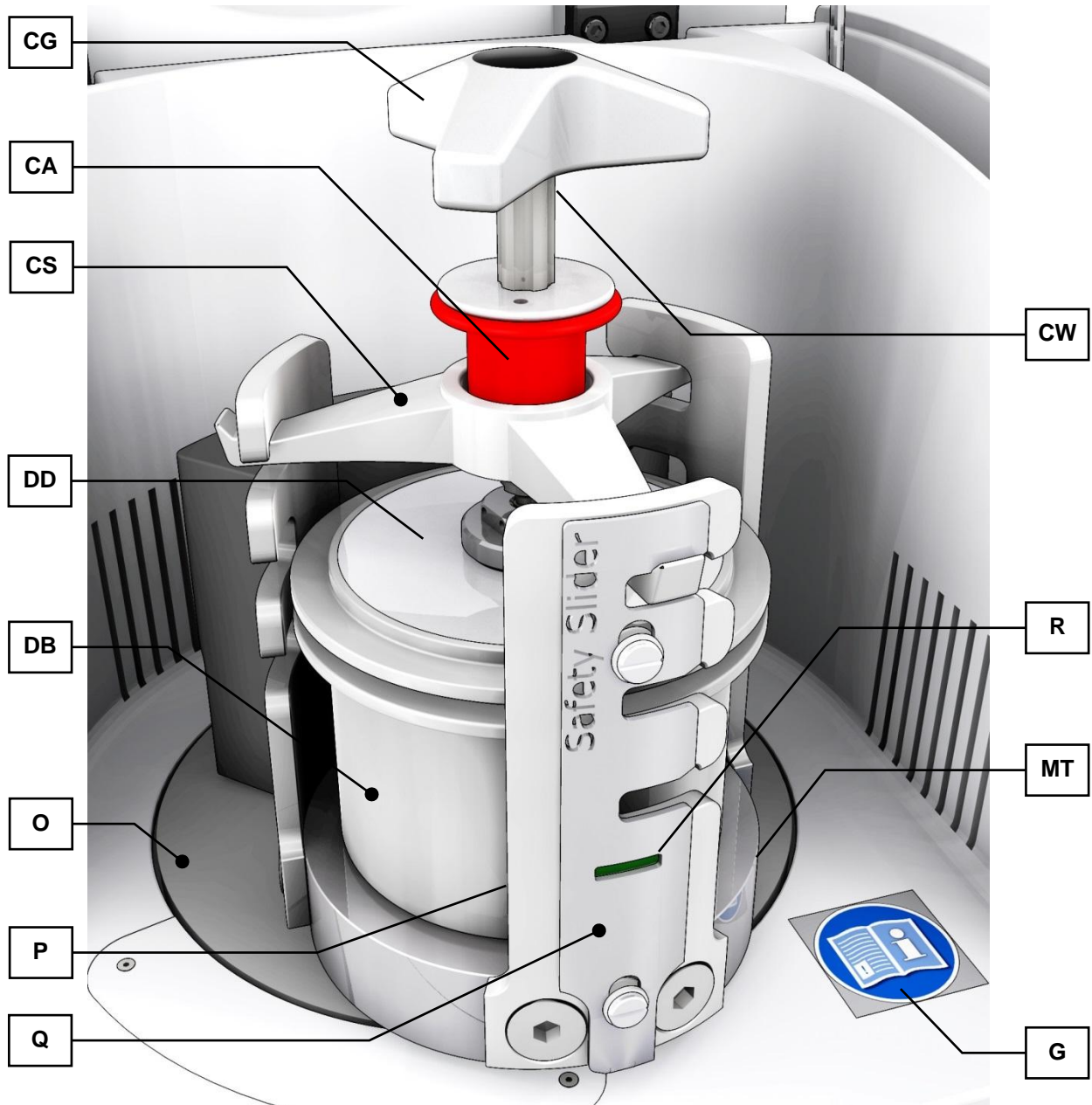

Fig. 8: Close-up of the grinding chamber

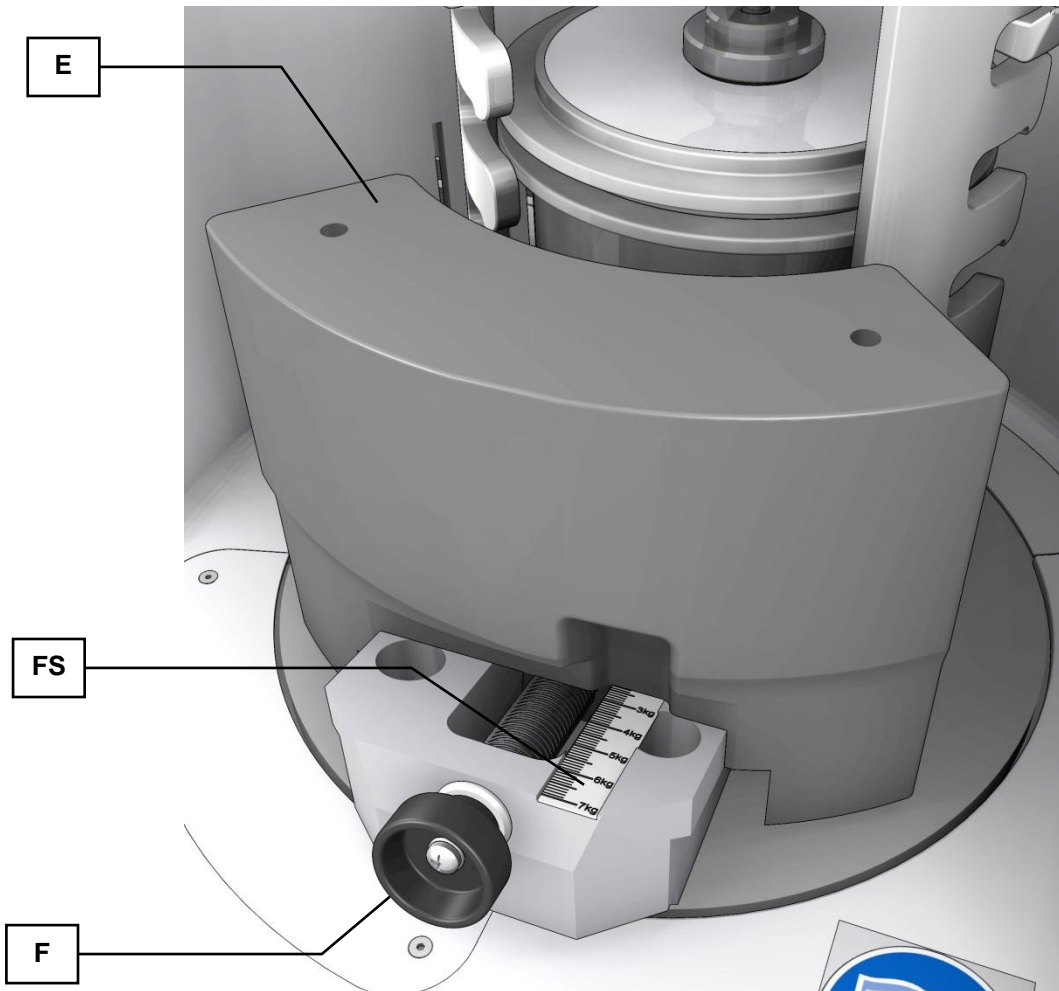

Fig. 9: View of counterweight



Fig. 10: View of the back of the device

5.2 Overview table of the parts of the device

Element	Description	Function
A	Cover	Closes the grinding chamber
B	Warning sign	Warning clamp grinding jar
C	Clamping unit for grinding jar	Clamps grinding jar on the support
CA	Locking sleeve	Prevents the twist grip from being turned accidentally
CG	Handle for clamping unit (lead frame)	Handle to clamp the grinding jars
CS	Base of clamping unit	Secures the clamping unit in the latching brackets
CW	Thread of clamping unit	Thread of clamping unit
DB	Grinding jar vessel	Sample vessel
DD	Grinding jar lid	Closes the sample vessel
E	Counterbalance weight	Counterbalance for the grinding jar
F	Rotary knob	Positions the counterbalance
FS	Weight scale	Adjusts the grinding jar weight
G	Sign with instruction to read the operating manual	Sign pointing out the need to read the operating manual
H	Pin closing mechanism	Safety lock for the cover
I	Damper for cover	Secures the cover when it is open
J	Closing mechanism for the opening	Support for pin closing mechanism
K	Control panel	Device controller
MT	Grinding jar plate	Support for the grinding jar
NR	Emergency release	Opening for the emergency release key
O	Turntable	Support for the grinding jar plate
P	Latching bracket	Supports the clamping unit
Q	Safety Slider	Safety component – checking whether the clamping unit is inserted and clamped
R	Display window	Displays the safety function
S	Serial interface	Interface for communication with the device
U	Main switch	Disconnects the device from the mains
V	Air opening	Air suction
W	IEC socket	Power supply for the power cable
X	Housing fan	Exhaust opening
Y	Type plate	Description of device parameters
Z	Warning sign to pull out the plug	Warning of electric shock

5.3 Operating elements and displays



Fig. 11: View of the control panel

5.4 Overview Table of the Operating Elements and the Display

Element	Description	Function
KR	Control knob (rotary/push button)	Rotary control to operate the device settings
KH	Button to open the cover	Unlocks the cover
KD	Display	Displays the control functions and parameters
KA	START button	Starts grinding
KO	STOP button	Stops grinding

5.5 Opening the device

The following steps are necessary to insert and clamp the grinding jar.

- Connect the device to the mains supply.
- Switch the main switch on the back on.
- Press the  button.

The safety lock opens and the lid can be opened

5.6 Closing the device

 **CAUTION**

V0084

Unsafe device state

Damage to the housing lid

The device may only be operated with undamaged housing lid.

- **If there is mechanical damage to the housing lid, this must be replaced for safety reasons.**

It is only possible to lock the grinding chamber if the device has been connected to the power supply and the main switch on the back of the device has been switched on.

- Close the housing lid.
 - A sensor detects the closing pin on the housing lid and the motorised lid closing mechanism is switched on.
 - The housing lid is automatically locked.

5.7 Emergency Unlocking

 **CAUTION**

Emergency Unlocking

Drive continuing to run

- There is a substantial risk of injury if the drive and associated device parts run on a long time without being braked!
- **Activate the emergency unlocking only when the machine has come to a complete stop and is disconnected from the power supply.**

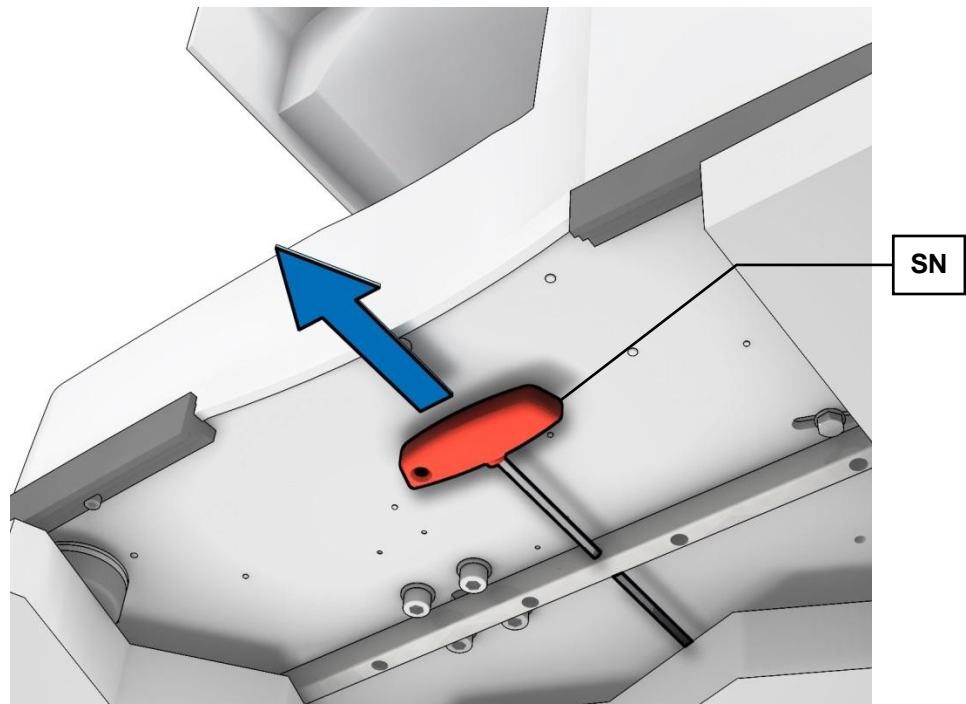

Fig. 12: Storage of key for emergency release

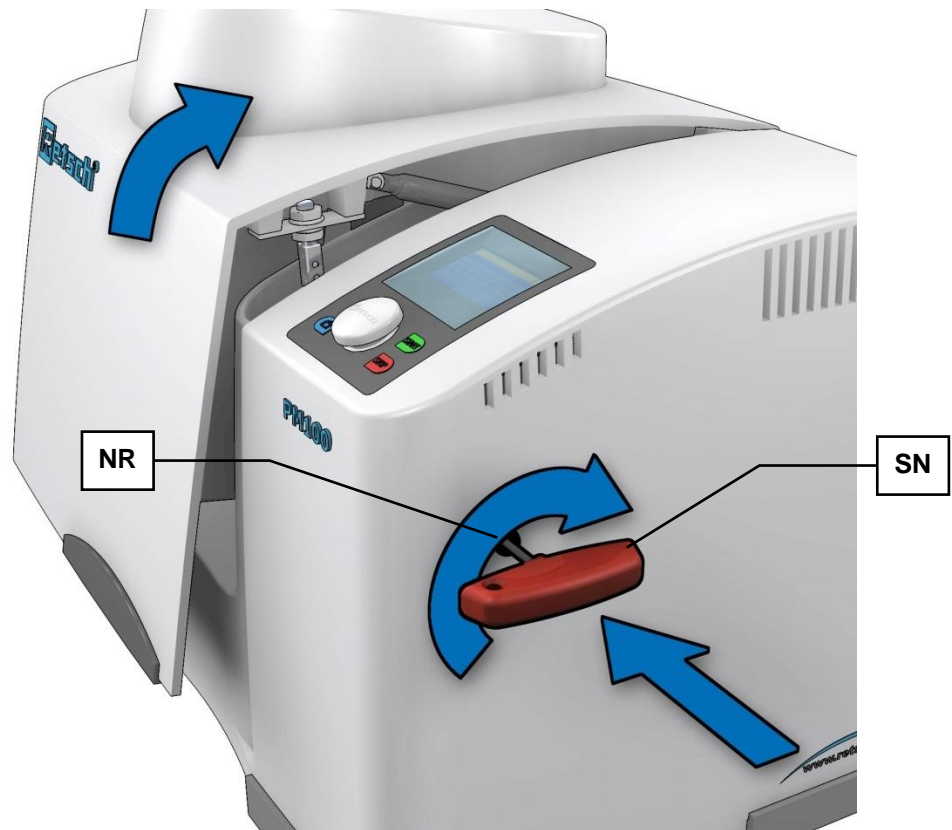

Fig. 13: Emergency release

A key is provided with the delivery of the device; this can be used to open the device manually in the case of a power failure .

- Insert the key (SN) into the opening (NR).
 - The key must be pressed in further with a little force to unlock the gear box.

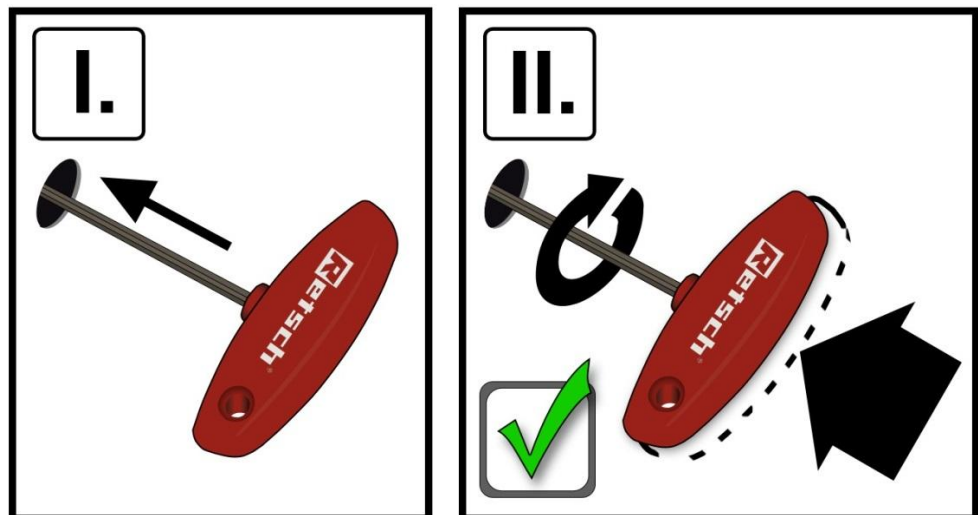

Fig. 14: Emergency release procedure

- Simultaneously twist the key (SN) anticlockwise as far as possible while pressing it in.
 - The lock is open and the lid can be lifted up.

5.8 Inserting the Grinding Jar

 **CAUTION**

V0049

Ejected objects

Grinding jar not clamped

- Grinding jars or clamping mechanisms can be ejected. This results in a risk of injury.
- **Never leave loose clamping devices without clamped grinding jars in the grinding jar support.**
- **Before starting the machine, ensure that all grinding jars are clamped.**
- **Ensure that the red sleeve of the clamping mechanism is clicked into place.**

- **In the case of extended grinding processes, check that the grinding jars are secure at the following intervals:
After 3 min, after 1h, after 5h then every 10-12h.**



 **CAUTION**

Scalding/burns

Hot grinding jar

- Depending on the grinding process, the material being ground and accordingly the grinding jar can become very hot.
- **Wear appropriate protection always when touching the grinding jar if it is hot.**
- **Never open hot grinding jars! Allow the grinding jars to cool down to room temperature before opening.**

NOTICE

H00681

Strong vibration and loud noise

Uneven load

- The device can produce very high levels of vibrations and noise when loading is uneven.
- **Always use 2 grinding jars opposite each other.**
- **The grinding stations must be operated with the identical grinding jars and with the same weight during each grinding process.**
- **Switch the device off immediately if there are high levels of vibration and noise, and check the number and gross weight of the jars.**

NOTE

Wear or damage of the device

Operation without grinding set

- During operation of the device without grinding set, excessive wear or damage to the device may occur.
- **Operate the device only with a grinding set mounted.**

NOTICE

H0011

Wear or damage to the grinding set

Different materials

- During the operation of the grinding set consisting of different materials, increased wear or damage to the grinding set is possible.
- **Only use grinding sets, where all parts are made of the same material.**

5.8.1 Inserting the grinding jar

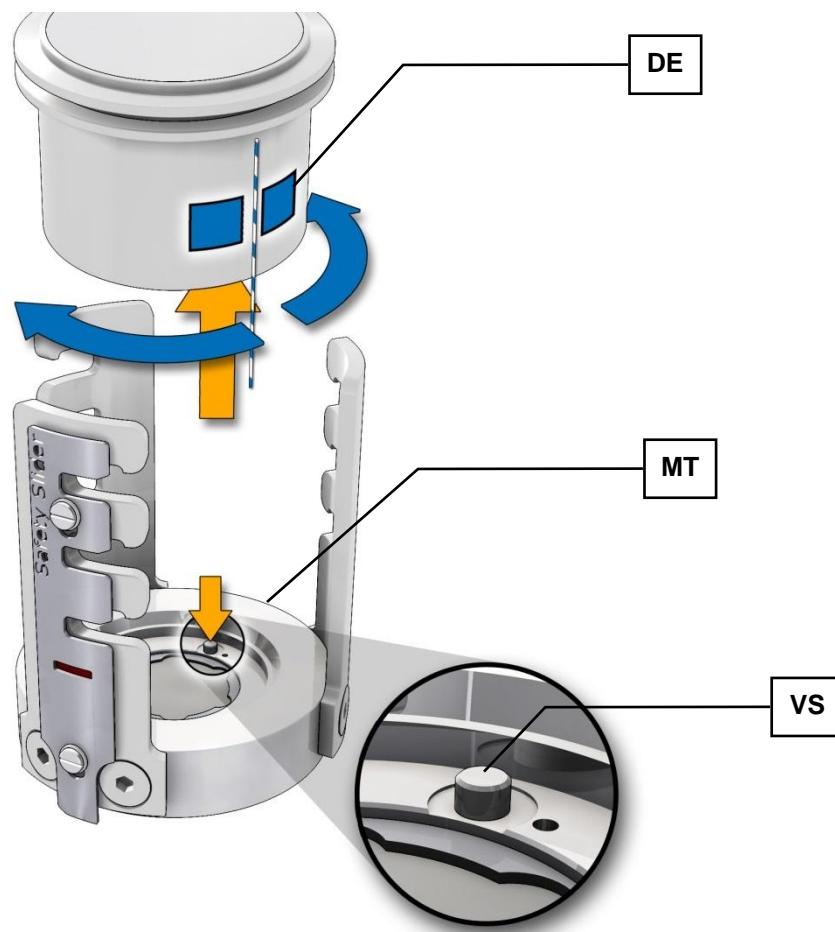

Fig. 15: Clamping the grinding jar

- If necessary clean the grinding jar plate (**MT**) and the anti-rotation pin (**VS**).
- Turn the grinding jar label (**DE**) to the same side as the anti-rotation pin.
- Place the grinding jar in the grinding jar support.

- Pay attention to the anti-rotation device when using 250 and 500 ml grinding jars. The hole drilled in the bottom of the grinding jar to support the anti-rotation pin (**VS**) is situated on the side of the lettering areas (**DE**).

5.8.2 Inserting the clamping unit

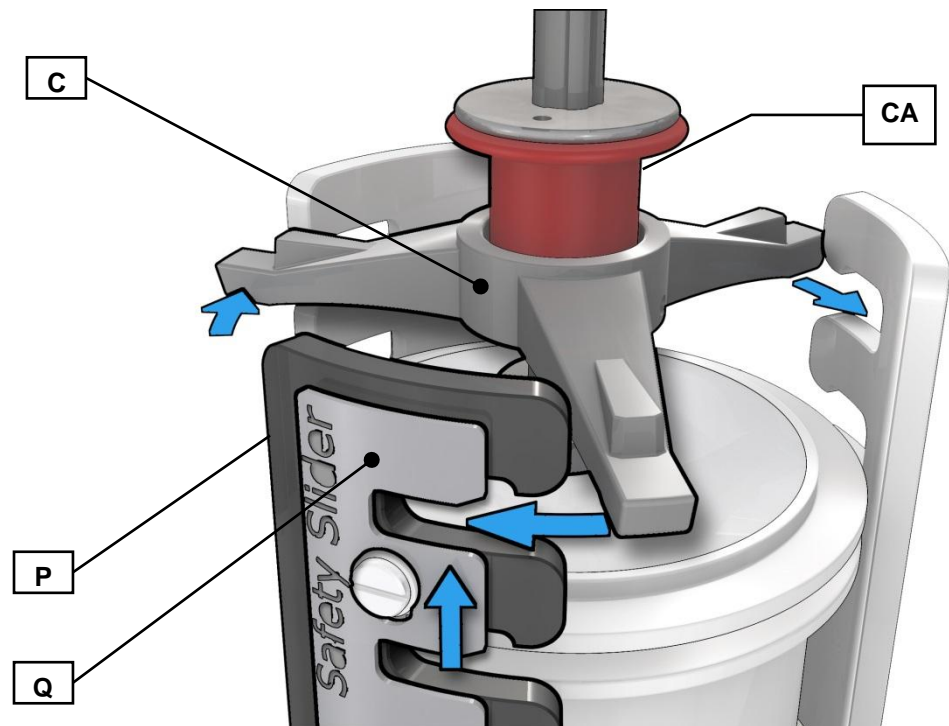

Fig. 16: Inserting the clamping unit

- Insert the clamping unit (**C**) in the three latching brackets (**Q**).

5.8.3 Function of the locking sleeve

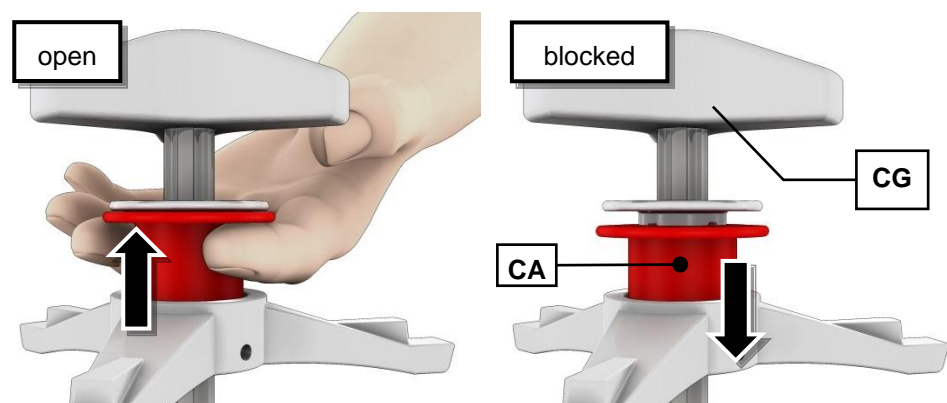

Fig. 17: Function of the locking sleeve

- Pull the red sleeve (**CA**) upwards and clamp the grinding jar by twisting the three-star grip (**CG**) to the right.
- Allow the red sleeve (**CA**) to audibly click down into place, if necessary tightening slightly using the three-star grip.
- It should no longer be possible to turn the three-star grip.
 - The red locking sleeve now in the blocked position stops the threaded spindle from coming loose automatically.

5.9 Balancing the device – only for the PM 100

Fig. 18: Balancing the device

The PM 100 must be balanced after inserting and clamping the grinding jar to ensure the device runs smoothly.

- Weigh the grinding jar with lid, ball filling and sample material.
- Slide the counterbalance weight (E) using the rotary control (F) until the edge (KA) of the scale (FS) shows the previously determined weight.

5.10 Balancing the device with additional weight – only for PM 100

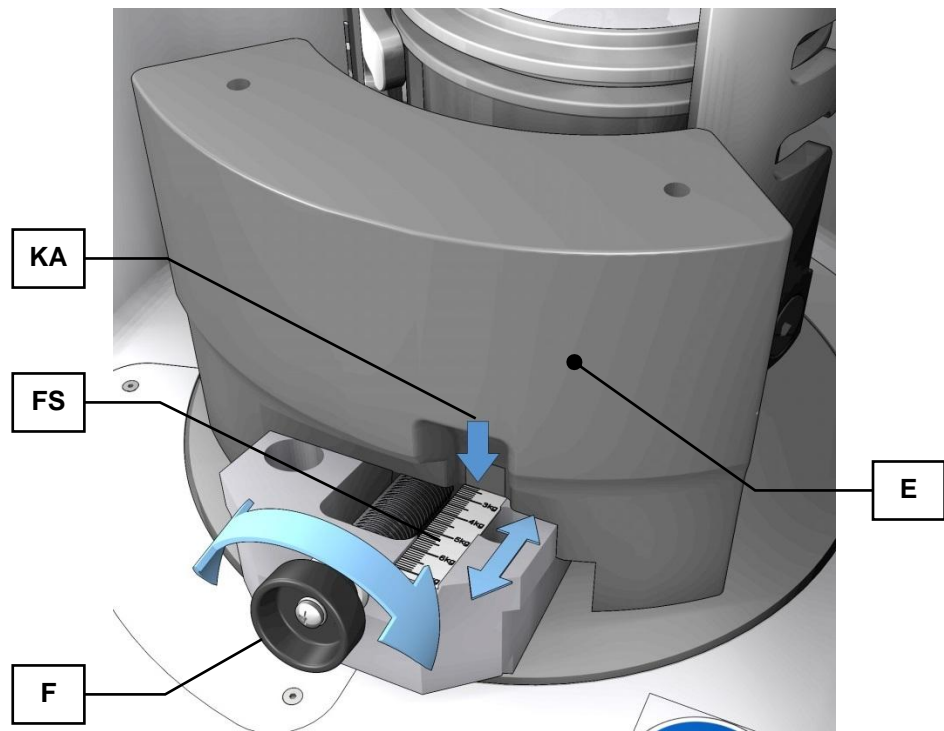
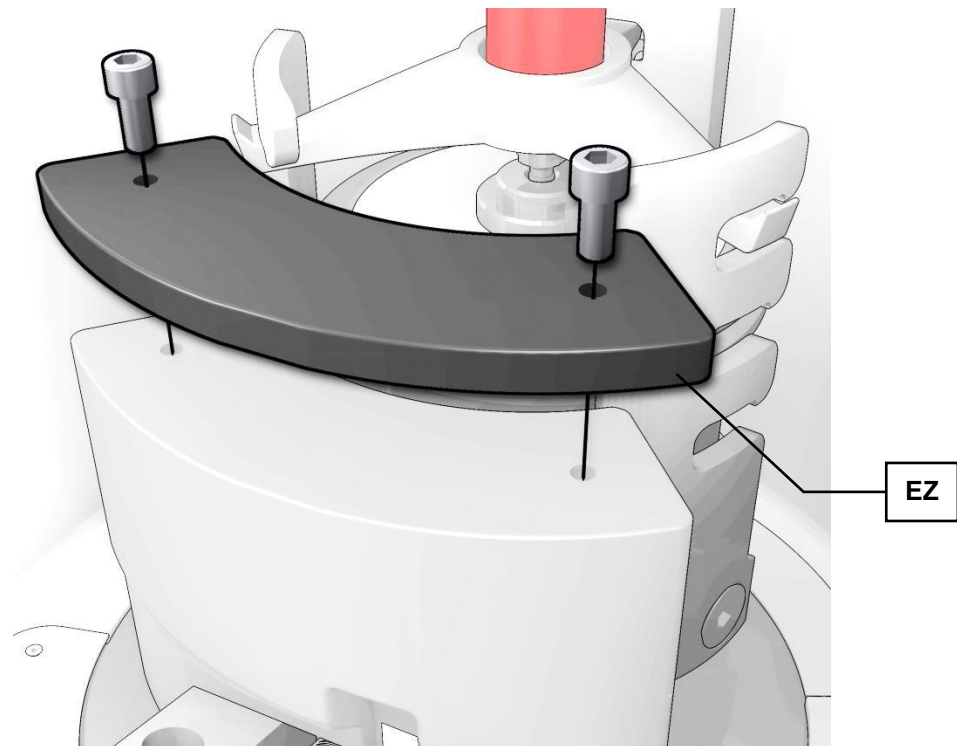

Fig. 19: Balancing the device

NOTICE

An additional 1 kg weight (**EZ**) is necessary when using the following grinding jars with safety closing mechanism!

5.10.1 Combination 1:

- Grinding jar 250 ml tungsten carbide 01.462.0497
- Safety closing mechanism 22.867.0012
- Grinding jar aeration cover 22.107.0621

5.10.2 Combination 2:

- Grinding jar 500 ml zirconium oxide 01.462.0504
- Safety closing mechanism 22.867.0012

NOTICE

Under some circumstances (filling), it may be necessary to use the additional weight when using the 500 ml zirconium oxide 01.462.0227 grinding jar!

5.10.3 Combination 3:

- Grinding jar 500 ml sintered aluminum oxide 01.462.0499
- Safety closing mechanism 22.867.0012
- If the additional weight is used (**EZ**), it is necessary to note that the scale no longer displays the correct weight (see below).
 - Order number additional weight: 22.221.0002
 - To secure the additional weight it is necessary to remove the two protective caps on the top of the counterweight.

- Screw the additional weight to the counterweight using the two cylinder head bolts (**EZ**).
- Tightening torque for the cylinder head bolts = 20Nm.
- After fitting the additional weight, the additional mass of 1.0 kg must be taken into consideration when reading off the scale!

Example:

If the grinding jar weighs 8.2 kg, the counterweight on the scale must be set to 7.2 kg.

NOTICE

The additional weight (**EZ**) must be removed again when using light (small) grinding jars!

5.11 Releasing the grinding jar clamping mechanism

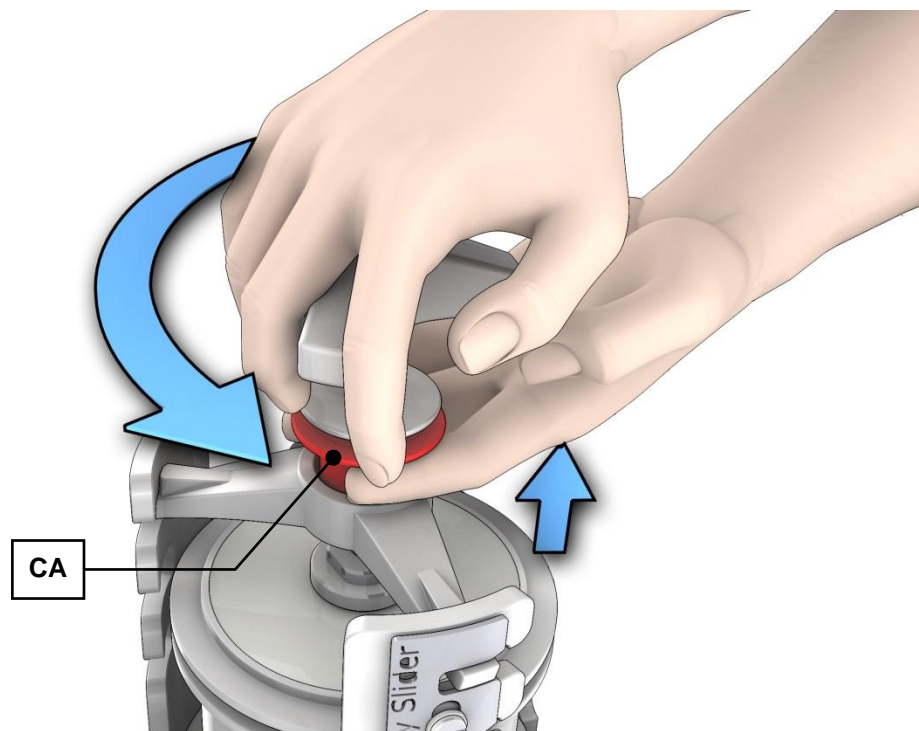

Fig. 20: Releasing the grinding jar clamping mechanism

- Pull the red sleeve (**CA**) upwards.
- Turn the three-star grip to the left to release the grinding jar.
 - Keep turning the three-star grip to the left until the grinding jar clamping mechanism can be removed.

5.12 Opening the Clamping Mechanism with the Opening Aid for the Clamping Unit

- The opening aid for the clamping unit (**KS**) [accessory] can be used to loosen or tighten the clamping unit (**C**).

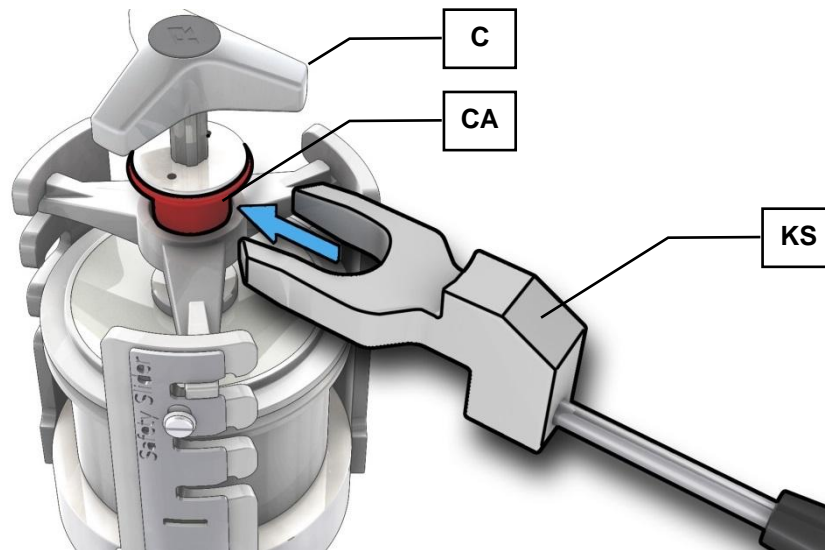

Fig. 21: Inserting the opening aid for the clamping unit on the PM 100

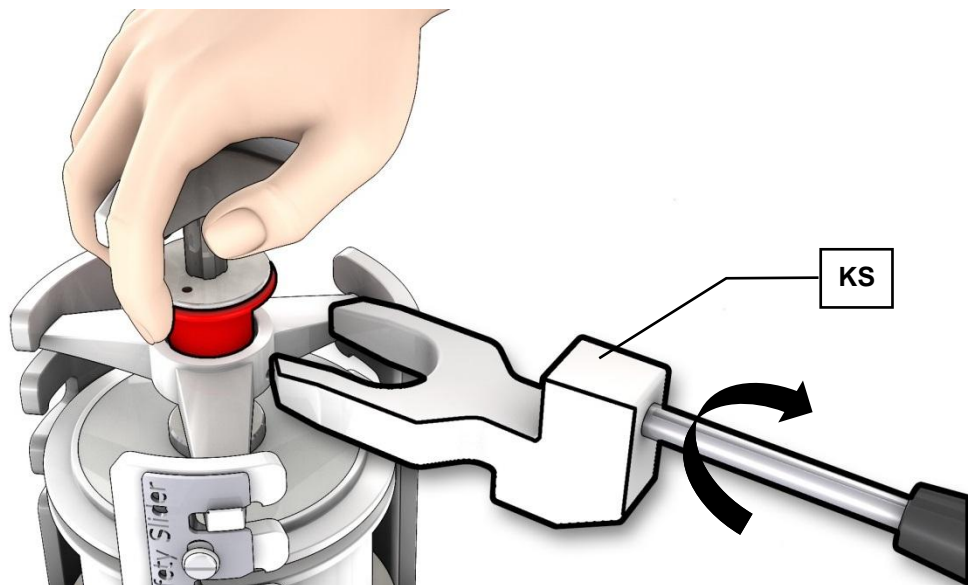

Fig. 22: Top latching position PM 200 – inserting the opening aid for the clamping unit

- With the PM 200, the opening aid for the clamping unit (**KS**) must be twisted 180° and pushed in when the grinding jar clamping mechanism is in the top latching position.
- When inserting the opening aid for the clamping unit (**KS**), the locking sleeve (**CA**) is pushed upwards and released.

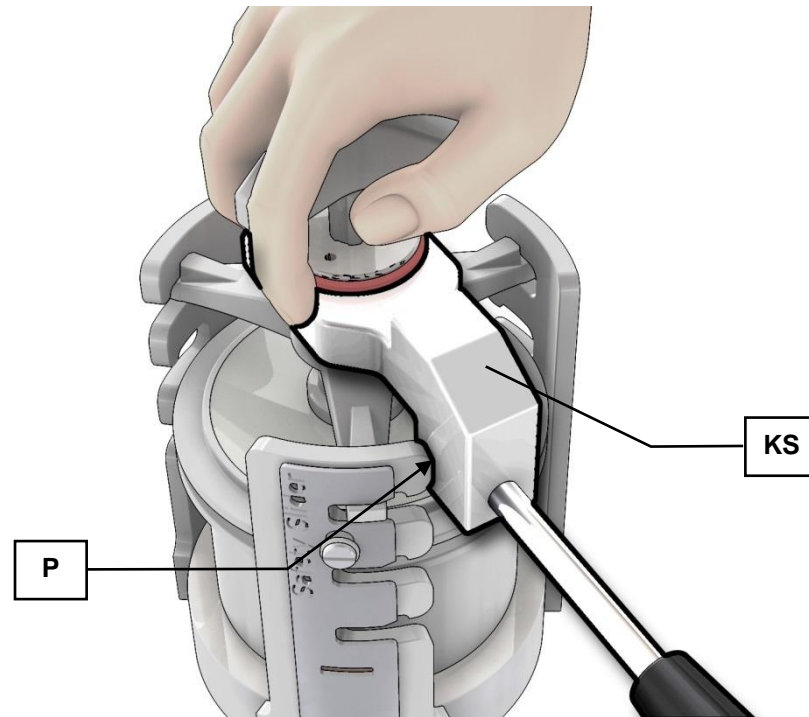

Fig. 23: Loosening the clamping unit

- Rest the opening aid for the clamping unit (**KS**) on the latching bracket (**P**) when closing and loosening.

5.13 Power failure during grinding

If the power fails during grinding, grinding will be interrupted. All parameters are retained, and the remaining grinding time is saved. When the device is switched on again, a corresponding message appears in the display.

You can continue the process by pressing the START button. The automatic saving of the remaining grinding time means the grinding then continues until the end of the originally set grinding time.

For safety reasons the device must be opened and the grinding chamber inspected. Grinding then continues automatically when the lid is closed.

The process is aborted by pressing the STOP button. .

5.14 Grinding Jar Selection for Different Sample Materials

This device is only suitable for use with grinding jars from Retsch GmbH with a nominal volume of 12 ml - 500 ml.

They are available in the following materials:

- Agate
- Sintered corundum
- Zirconium oxide
- Stainless steel
- Special steel
- Tungsten carbide

5.15 Sample quantity

NOTICE

If the fill level in the grinding jar is too high or too low, this will impair the milling result and may cause damage (increased abrasion) to the grinding set.

5.15.1 Guides for material quantity and balls

The PM 100 is only suitable for grinding jars with a nominal volume of 12-500 ml.

The PM 200 is only suitable for grinding jars with a nominal volume of 12-125 ml.

Grinding jar volume	Sample volume	Max. feed size	Ball filling (each)					
			Ø 5 mm	Ø 7 mm	Ø 10 mm	Ø 15 mm	Ø 20 mm	Ø 30 mm
12 ml	≤ 5 ml	< 1 mm	50	15	5	-	-	-
25 ml	≤ 10 ml	< 1 mm	95-100	25-30	10	-	-	-
50 ml	5 - 20 ml	< 3 mm	200	50-70	20	7	3-4	-
80 ml	10 - 35 ml	< 4 mm	250-330	70-120	30-40	12	5	-
125 ml	15 - 50 ml	< 4 mm	500	110-180	50-60	18	7	-
250 ml	25 - 120 ml	< 6 mm	1100-1200	220-350	100-120	35-45	15	5
500 ml	75 - 220 ml	< 10 mm	2000	440-700	200-230	70	25	8

In addition to the instrument settings, the filling level of the grinding jar is also of crucial importance for a successful grinding process in the Planetary Ball Mill of Retsch GmbH. The usable capacity of the grinding bowls depends on the type of material. The specified number of balls is the minimum quantity per grinding bowl. An optimal grinding result is achieved with the larger number of permissible grinding balls, if specified. In exceptional cases, the number of grinding balls can be reduced by up to 15 %, but then increased abrasion of the grinding set must be expected.

When grinding bulk materials, the grinding jar filling should consist of approximately one third of sample and one third of ball quantity. The remaining third is the free grinding jar volume, which is required for the movement of the balls.

If an increase or decrease in sample volume is to be expected during the grinding process, the amount of sample can be adjusted within the range listed in the table. Thus, e.g. for voluminous materials such as wool, leaves, grasses and similar, a material filling level of 70 – 80 % is necessary. For wet grinding with grinding balls < 3 mm, the ball charge should be 60 % of the grinding jar volume.

5.16 Ultrafine grinding

High degrees of fineness can frequently only be achieved using wet grinding.

Improved final fineness can be achieved in dry grinding by adding a few drops of stearin or acetic acid and by using grinding balls with a $\varnothing < 10\text{mm}$ and a fill level of 70-80% of the grinding jar volume.

5.17 Stacking the grinding jars

PM 100: Stacking of grinding jars is possible in the sizes 12 ml, 25 ml, 50 ml and 80 ml.

PM 200: Stacking of grinding jars is possible in the sizes 12 ml and 25 ml.

A maximum of two grinding jars may be stacked on top of each other.

In order to insert and stack specific grinding jars, you may need the adapters which are available as accessories.

5.17.1 Stacking the 50 ml and 80 ml grinding jars

PM 100: 50 ml grinding jars in Comfort design and 50 ml and 80 ml grinding jars in EasyFit design can be stacked. You may need the adapters which are available as accessories for stacking.

PM 200: It is not possible to stack 50 ml and 80 ml grinding jars.

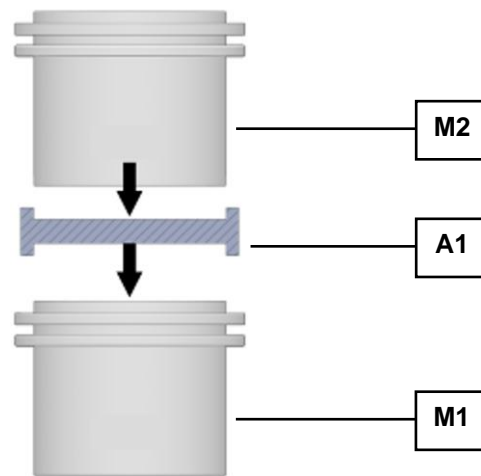

Fig. 24: Stacking grinding jars on the PM 100

Stacking process:

- Place the grinding jar (**M1**) in the grinding jar plate
- Place the adapter (**A1**) on the lid of M1
- Place grinding jar (**M2**) on the adapter
- Clamp the grinding jars as described in the chapter "Clamping the grinding jars".

5.17.2 Stacking the 25 ml and 12 ml grinding jars

Grinding jars with a capacity of less than 50 ml can be stacked on top of each other directly without the use of accessories.

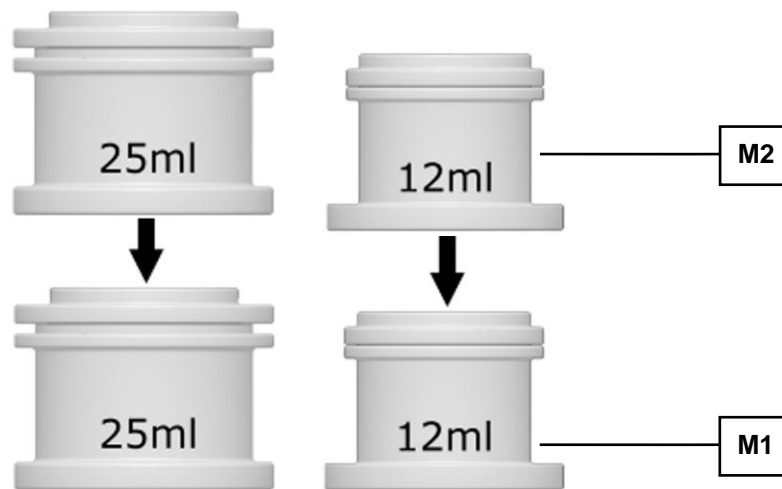

Fig. 25: Stacking the 25 ml and 12 ml grinding jars

Stacking process:

- Place the grinding jar (**M2**) directly on top of grinding jar (**M1**).
- Clamp the grinding jars as described in the chapter “Clamping the grinding jars”.

5.18 Handling grinding jars

 **CAUTION**

Scalding/burns

Hot grinding jar

- Depending on the grinding process, the material being ground and accordingly the grinding jar can become very hot.
- **Wear appropriate protection always when touching the grinding jar if it is hot.**
- **Never open hot grinding jars! Allow the grinding jars to cool down to room temperature before opening.**

5.18.1 Carrying and gripping



Fig. 26: Grinding jar gripping flanges
The gripping flanges (**GR**) on the grinding jar lid permit secure handling.

5.18.2 Anti-rotation device

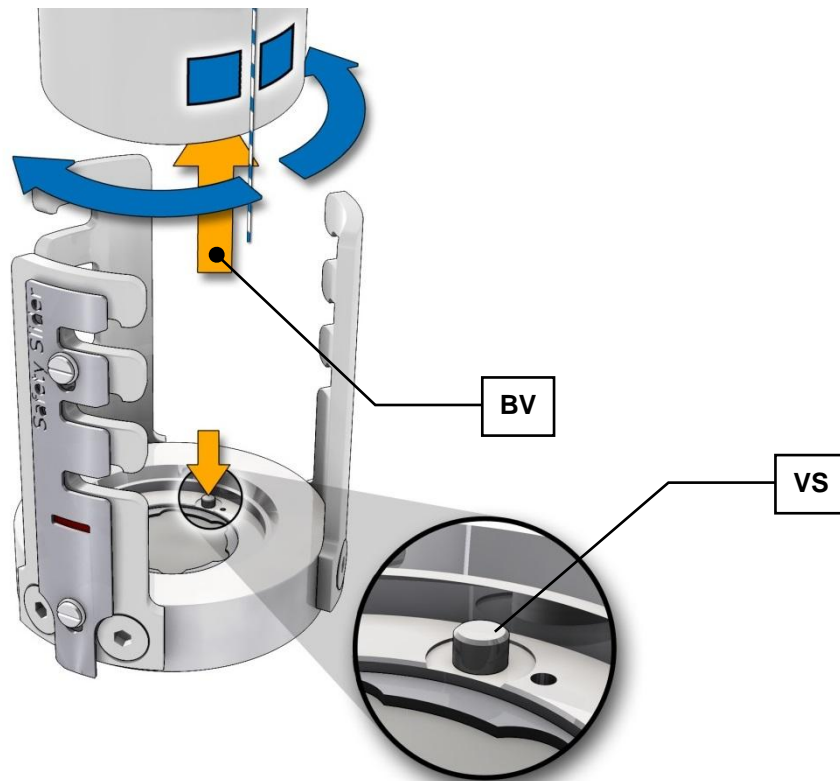

Fig. 27: Anti-rotation device
All 250 ml and 500 ml grinding jars have a drilled hole (**BV**) underneath the grinding jar as anti-rotation device. The anti-rotation device is only used with the PM 100 and is located on the side of the grinding jar casing with lettering.

5.18.3 Heating the grinding jars

Depending on the grinding time and the fill level, the grinding jars can be heated to a temperature of up to 150°C during grinding.
This temperature change causes the pressure inside the grinding jar to increase. When unscrewing the lid, please note that this excess pressure is released by a sudden escape of air. This may be accompanied by particles of sample material.

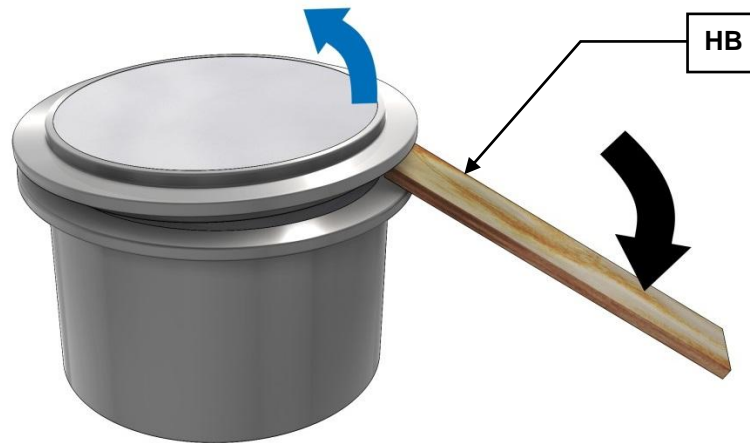

Fig. 28: Prising the grinding jar lid open

When grinding jars have been left to cool, a vacuum is created inside them which can make them difficult to open. The grinding jars can be prised open between the gripping flanges on the lid and the grinding jar, e.g. using a flat wooden stick (**HB**).

5.19 Grinding jar identification

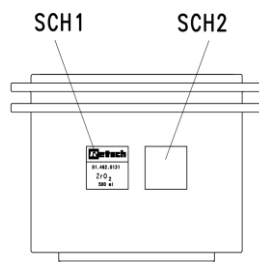

Fig. 29: Grinding jar lettering

All grinding jars can be identified by a labelling field which shows the article number and material (**SCH1**).

5.19.1 Customer labelling on the grinding jar

In addition to the labelling field specified above, you can stick one of the supplied labels or labels obtainable as accessories to the area on the grinding jar indicated (**SCH2**) to provide information about the grinding jar content for example.

The label is heat resistant to 150°C and can be cleaned using alcohol or acetone to remove any lettering you have applied.

5.20 Grinding jar cleaning



Fig. 30: Removing the O-ring

The O-ring (**OR**) on the groove (**NU**) on the underneath of the lid can be lifted out easily to clean the grinding jar.

Grinding jars, including those with glued ceramic inserts, can be cleaned using alcohol, benzine or normal household detergents.

NOTICE

When cleaning, do not expose grinding jars with ceramic inserts to sudden temperature differences.

Sudden temperature fluctuations can cause the ceramic inserts to crack.

5.20.1 Drying the grinding jars

After cleaning, the grinding jars can be dried in the drier cabinet at the temperatures specified below.

Material of the grinding jars	Temperature
Hardened stainless steel	up to 200°C
Tungsten carbide	up to 120°C
Sintered corundum	up to 120°C
Agate	up to 120°C
Zirconium oxide	up to 120°C

5.21 Opening and closing of the grinding jars with safety locking device

A safety locking device is recommended for grinding processes (especially wet grinding) where an increase in pressure is to be expected in the grinding jar. If a gassing lid is used, the grinding jar must also be sealed with a safety sealing device.

NOTE

For Comfort design grinding jars, the safety sealing device must always be selected taking into account the grinding jar size and material.

The use of agate grinding jars for wet grinding with solvents should be given particular consideration due to the internal pressures that arise and the non-homogeneous material properties of a natural product.

The type of safety locking device must be adapted to the grinding jar used. The safety locking device with two clamping rings must be used for grinding bowls in the Comfort design and with locking hooks for grinding bowls in the EasyFit design. No product combinations other than those described here may be used!



Fig. 31: A Comfort design grinding jar (left) and an EasyFit design (right)



Fig. 32: Safety locking device for Comfort design grinding jars

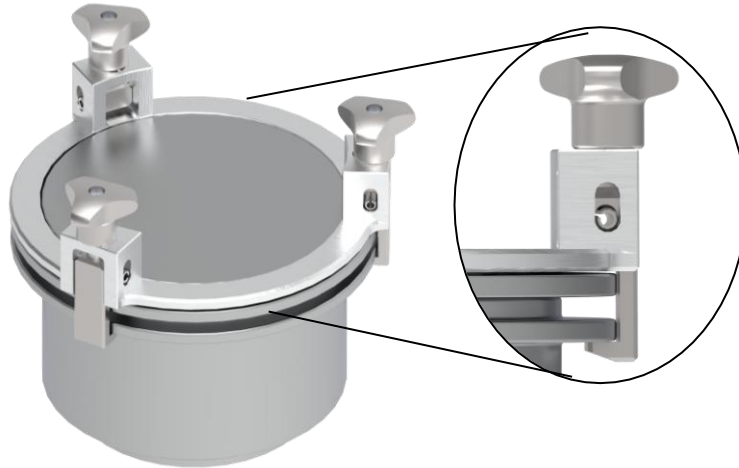

Fig. 33: Safety locking device for EasyFit design grinding jars

Tighten the screw connection on the safety locking device alternately and gradually. Tightening unevenly can cause the cover and the safety locking device to tilt!

With the safety locking device for grinding jars in the Comfort design, the three clamping screws must be tightened to 2.5 Nm.

With the safety locking device for grinding jars in the EasyFit design, the three clamping screws (using the opening and closing aid) must be tightened to at least 8 Nm.

Internal pressures up to a max. 5 bar are only permissible with this pre-tensioning.

NOTE

Damage to the grinding jar lid and the appliance.

The three screws on the safety clip of the gassing cover can loosen and damage the inside of the appliance.

After tightening the grinding jar clamping device, check whether the three screws on the safety locking device are still tight.

NOTE

The appliance is equipped with a fan that extracts the waste heat generated during grinding directly from the grinding chamber. The extraction volume per hour is more than 20 times the grinding chamber volume. The fan has a standstill monitor with signalling.

If necessary, divert the air flow from the fan into a fume cabinet during grinding.

Before removing the grinding jar, check that the safety locking device is firmly in place.

Only remove the grinding jar with the safety locking device and only open it in a safe position (suction device) after it has cooled down.

5.22 Wet Grinding with Highly Flammable Materials

Wet grindings using highly flammable materials are permissible with this device when complying with specific precautionary measures.

When using highly flammable materials as grinding aid, such as hexane, isopropanol, ethanol, petrol or similar, it is to be assumed that the inside of the grinding jars should be classified as zone 0, i.e. a constantly present explosive mix.

Therefore, it is necessary to prevent potentially explosive vapours during the grinding process from escaping from the clamped grinding jars and from entering areas in which the requisite ignition energy is present. These vapours may be pressed out of the grinding jar in particular by the heating which takes place and the resulting pressure increase inside the grinding jar.

It is therefore urgently recommended that the managing operator (employer) using the device assesses the dangers that exist before using corresponding solvents, taking local conditions into account, as part of a coherent explosion protection concept. If necessary, supplementary organisational measures should be recorded in writing in an explosion protection document.

This procedure is regulated in the EU under Articles 118 and 118a of Directive 89/391/EEC. In other countries outside the EU, the comparable provisions are to be observed.

The following must be verified with respect to the device:

- **Only grinding jars with safety closure devices may be used!**
- It is necessary to consider the durability of the O-rings (EPDM 75° shore) when selecting the solvent and the durability of the adhesive used when using ceramic inserts.
- The safety closure devices of the grinding jars must be tightened firmly.
- Please note that the grinding jars can heat up considerably depending on the grinding jar size, the ball filling, the speed and the grinding duration.
- Before removing the grinding jars, the tightness of the safety closure devices must be checked anew.

6 Display and operation

6.1 Symbols in the Display Unit

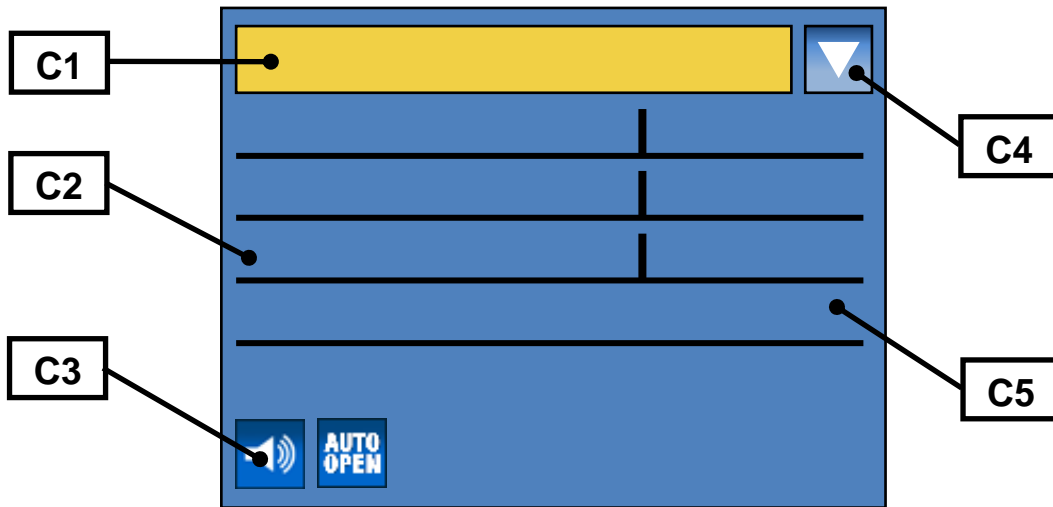

Fig. 34: View of the menu on the display unit

Element	Description	Function
C1	Menu navigation	Switching between manual operating mode, program and basic settings
C2	Specification of grinding parameters	Displaying and setting grinding parameters
C3	Icons for device functions	Displaying the function statuses of sound, automatic opening and grinding jar recognition
C4	Icon for scrolling direction	Displays the possible scrolling directions
C5	Grinding parameters	Display of values

	Automatic opening switched on
	Automatic opening switched off
	Direction reversal switched on
	Direction reversal switched off
°C	Motor or frequency converter too hot
Power	Grinding output display
	Acoustic warning signal on
	Acoustic warning signal off
	Scrolling upwards or downwards possible
	Only scrolling upwards possible
	Only scrolling downwards possible

6.2 Display unit – operation of the device

This device offers a new, very convenient user interface. All relevant data can be entered and retrieved using a graphics display with one-button operation. The menu is available in different languages.

6.2.1 Adjustment options using the display menu

The selection bar in the display should be operated as follows:

Rotating function I)

- Rotate the operating button to get to the different menu items. The selected menu items are marked by the dark selection bar. Areas that cannot be changed are skipped.

Rotating function II)

- Rotate the operating button to change numerical values and decisions in the menu items.

Press I)

- Press the operating button to open selected menu items.

Press II)

- Press the operating button to confirm settings.

Press III)

- Keeping the operating button pressed for longer takes you back to the basic screen (Level 1).

6.2.2 Navigating between operating modes

- Rotate the operating button in a clockwise direction until the dark line cursor is in the navigation menu (**C1**).
- Press the operating button (**F**).
- The icon for the scrolling direction (**C4**) changes from



- By pressing the operating button, navigate between manual operation, Programs 01 to 10 and the basic settings operating modes.
- Press the operating button (**F**) to activate the selected operating mode.
- The icon for the scrolling direction (**C4**) changes from

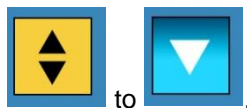

- By rotating the operating button, switch to the sub-items of the selected menu item.

6.3 Direct access to the language menu

If you have unintentionally set the wrong language, you can go straight to the language menu by following the steps below.

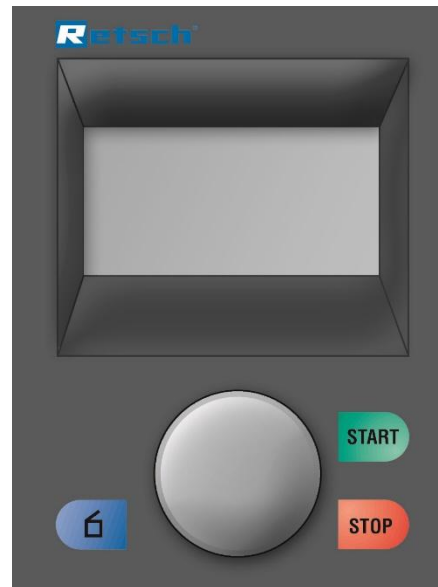

- Switch the device off at the main switch.
 - Switch the device on while simultaneously pressing the buttons **START - STOP – Open hood**.
 - After selecting the correct language, switch the device off and then immediately back on.
- Confirm your selection by pressing the operating button.

The device is now set permanently to your language and you are in the main menu.

6.4 Menu structure

Complete summary of all menu options:

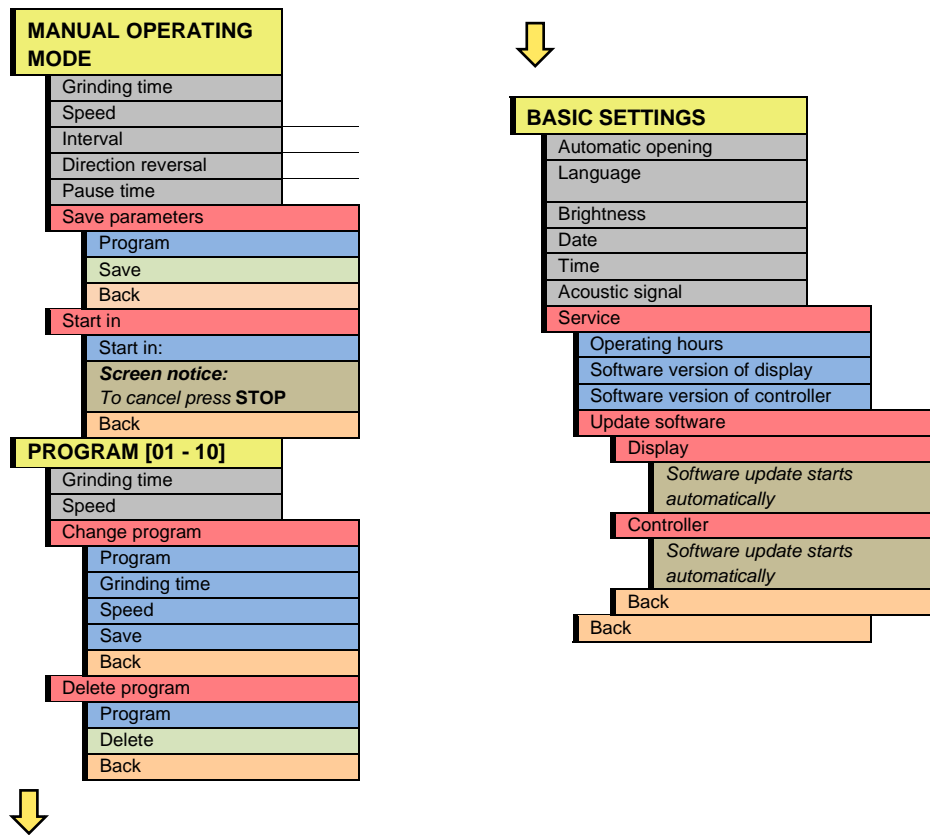

6.5 Operating modes

You can select the following operating modes using the menu navigation (C1):

6.5.1 Manual operation

When this function has been set you can access and change all parameters and functions at any time. This is also possible during grinding.

6.5.2 Program 01 to 10

In programs 01 to 10 the previously set parameters for grinding time and speed can be saved to a memory.

6.5.3 Basic settings

You can adjust the following device settings in this settings menu:

- Automatic opening
- Language
- Brightness
- Date
- Time
- Acoustic warning signal
- Service

6.6 Manual Mode

6.6.1 Grinding time

The device is started with the preselected grinding time and at the last speed used. Direction reversal with pause time has not been switched on

6.6.2 Speed

The device is started with the preselected grinding time and at the last speed used. Direction reversal with pause time has not been switched on

6.6.3 Interval

The interval time can be set here according to the grinding time. If no interval has been set, no direction reversal can be set.

6.6.4 Direction reversal

On/off

The device is started with the preselected grinding time, speed and direction reversal. The machine rotates in one direction for the set interval time, comes to a halt and starts again immediately in the other direction without a pause time.

6.6.5 Pause time

The pause time between intervals can be set here.

No pause time can be set if no interval has been set.

The device is started with the preselected grinding time, speed, direction reversal and set pause time. The machine rotates in one direction for the set interval time and comes to a halt; once it has stopped, the previously set pause time is displayed during the set interval time and counts down to 00:00:00.

The device starts again in the other direction when the pause time has expired.

6.6.6 Save parameters

The previously set parameters such as grinding time and speed can be saved in a memory here.

- Set the desired parameters.
 - By turning the control knob (F), switch to the **Save parameters** menu option.
 - Press the control knob (F).
 - The **Save parameters** menu opens and the dark cursor line is on **Program**.
 - Press the control knob (F) to select a program memory location.
 - By turning the control knob (F), switch to the desired memory location.
 - Press the control knob (F) to exit the memory location selection.
 - Select either
 - **Save** to save settings or
 - **Back** to cancel without saving.

6.6.7 Start in

You can set a countdown for starting the device here.

- Press the STOP button to cancel the countdown.

6.7 Programme Mode

6.7.1 Change program

You can change the saved parameters for any program in this menu.

- By turning the control knob (F), switch to the **Change program** menu option.
- Press the control knob (F).
- The **Change program** menu opens and the dark cursor line is on **Program**.

NOTICE

You can change the active program or any other program.

- Press the control knob (F) to activate the program selection.
- By turning the control knob (F), switch to the desired memory location.
- Press the control knob (F) to exit the memory location selection.
- Adjust the desired grinding parameters.
- Finally select either
 - **Save** to save settings or
 - **Back** to cancel without saving.
- This takes you back to the Program level.

NOTICE

It is not possible to start a program that has not been saved.

6.7.2 Delete program

You can delete the saved parameters for any program in this menu.

NOTICE

Only the saved parameters for the program concerned are deleted. The program memory location continues to exist.

- By turning the control knob (F), switch to the **Delete program** menu option.
- Press the control knob (F).
- The **Delete program** menu opens and the dark cursor line is on **Program**.
- Press the control knob (F) to activate the program selection.
- By turning the control knob (F), switch to the desired program.

- Press the control knob (F) to exit the program selection.
 - Finally select either
 - Delete to delete the settings or
 - Back to cancel without deleting.
- This takes you back to the Program level.

6.8 Basic settings

NOTICE

It is not possible to begin grinding while the basic settings menu is active.

6.8.1 Automatic opening

In this menu you can set whether the grinding jar lid opens automatically when grinding ends or only when the button is pressed.

If the function is switched off, the following pictogram appears on the display as confirmation.



Fig. 35: Automatic opening pictogram

6.8.2 Language

You can select the menu language here. After selecting and pressing the control knob, the entire menu structure is displayed in your language.

NOTICE

The language menu is displayed when the device is switched on for the first time.

- Select the desired language by turning the control knob.
- Press to confirm the selection; “open lid” appears on the display.

6.8.3 Brightness

The brightness can be adjusted to suit the respective user or environment (sunshine, glare etc.).

6.8.4 Date

The current date can be entered here.

The device can be disconnected from the mains for up to 30 days before the settings are lost.

6.8.5 Time

The time can be entered here.

The time then appears in the stand-by monitor.

The device can be disconnected from the mains for up to 30 days before the settings are lost.

6.8.6 Acoustic warning signal

Error messages indicating incorrect operation can be supported by an acoustic warning signal.

The corresponding pictogram appears if the function has been switched off

6.8.7 Service

6.8.7.1 Operating hours

Grinding hours are counted, i.e. the total times between START and STOP. It is not possible to manipulate the times.

6.8.7.2 Software version of display

Shows the software version of the display.

6.8.7.3 Software version of the controller

Shows the version of the operating software .

6.8.7.4 Update software

SOFTWARE VERSION

The version of the operating software can be called up and updated as required. If necessary, get in touch with your Retsch distributor.

Should you have reached this menu by mistake and cannot return to the previous menu, switch the device off at the main switch and re-start it.

6.8.7.4.1 Safety notice

For many years the grinding jar clamping mechanism has been a proven, easy to use and reliable device. The basic prerequisite both for the safety of the operator and for the life of the machine components is careful clamping of the grinding jars.

Please remember that this device involves grinding equipment which applies very high amounts of energy into the sample material, and that the grinding set therefore needs to be locked into position carefully.

Correct securing of the grinding jar is always queried prior to starting the machine in order to prevent operating errors.

Employees who have been especially trained and who are familiar with operation of the PM can also permanently fade out this safety notice. We do not recommend this course of action, particularly when there are changes in operating staff!

The device software is set up such that the displayed message about clamping the grinding jars must be confirmed whenever the start button is actuated prior to starting the machine.

The grinding process begins after confirmation.

This safety notice can be faded out in the "Settings" menu.

7 Fault messages

Error code	DEFECT DESCRIPTION TRANSLATION
E10	DRIVE OVERLOAD
E20	FAILURE MAIN BOARD
E23	FAILURE FAN
E25	FAILURE DISPLAY
E26	FAILURE FREQUENCY CONVERTER
E41	FAILURE SPEED SENSOR
E47	OUT OF BALANCE
E50	FAILURE IN SAFETY CIRCUIT
H10	ALLOW DRIVE TO COOL DOWN
H13	OVERLOAD! REDUCE SPEED!
H14	OVERLOAD! SPEED HAS BEEN REDUCED!
H42	OPEN AND CLOSE LID/COVER
H45	MAINS INTERRUPTION

8 Installing additional equipment

By means of the Retsch additional equipment, the planetary ball mills PM 100, PM 300 and PM 400 can be flexibly adapted to different working conditions.

The following additional equipment is available for the Retsch planetary ball mills PM 100, PM 300 and PM 400:

- Adapter for 24 x 1.5 ml glass vials
- Adapter for 7 x 20 ml glass vials

⚠ CAUTION If the additional equipment is loaded incorrectly, the grinding vessels may splinter during the grinding process. Please observe the specifications regarding the sizes of the grinding balls and the maximum permitted speeds.

8.1 Adapter for glass vials

NOTICE

Strong vibration and loud noise

Uneven load

- The device can produce very high levels of vibrations and noise when loading is uneven.
- **Always use 2 grinding jars opposite each other.**
- **The grinding stations must be operated with the identical grinding jars and with the same weight during each grinding process.**
- **Switch the device off immediately if there are high levels of vibration and noise and check the number and gross weight of the jars.**

The device can be equipped with an adapter for glass vials. The adapters enable the simultaneous use of up to 24 x 1.5 ml or 7 x 20 ml samples in the respective vials.

Mount the adapter as follows:

NOTICE Always fit the adapter in a symmetrical arrangement. Otherwise, the grinding jar lid may tilt and the adapter may not be clamped properly.

⇒ Insert the compressure spring into the desired opening of the adapter.

⇒ Place the loaded and closed glass vial on the compressure spring with the lid facing upwards. The tension of the spring pushes the vial upwards.

⇒ Insert the loaded adapter into the grinding jar support of the desired device.

Close the adapter with the lid and secure it with the clamping unit. It must be ensured that the lid sits straight and is firmly clamped in place.

⚠ WARNING Please observe the instructions in the operating instructions for your device regarding the safe handling of the clamping unit. The lid must close the adapter flush and must not rest at an angle!

⇒ Alternatively, the lid of the adapter can also be secured with the safety locking device for grinding jars. In such a case, load the adapter as described above, put on the lid and tighten the safety locking device. Subsequently, insert the closed adapter into the grinding jar support.

NOTICE In order to reduce wear and tear on the compressure springs, it is recommended that only springs are inserted into the openings of the adapter which are loaded with vials.

⚠ CAUTION The clamping force of the compressure springs pushes the inserted vials out of the adapter. Therefore, transport the adapter which is loaded with vials without the lid. Alternatively, secure the lid with the safety locking device.



Fig. 36: Exploded view of the adapter with compressure spring and 1.5 ml vial



Fig. 37: Permissible arrangement of the glass vials in the adapter

⚠ CAUTION Glass vials are not suitable for grinding hard-brittle materials. These are disposable glass vials which must not be used more than once. Please observe the maximum speed specifications.

⚠ CAUTION Glass vials can break and cause cuts!

The filling of the vials deviates specifically from the 1/3 rule in terms of application and filling:

Example 1 (1.5 ml)	
Grinding balls	2 – 4 x 3 mm grinding balls, stainless steel
Sample material/ Mixture of reactants	20 % filling volume of the vial, top up with a few µl of solvent

Example 2 (1.5 ml)	
Grinding balls	approx. 1/3 of the glass vial with 3 mm grinding balls, stainless steel
Sample material/ Mixture of reactants	max. 20 % filling volume of the vial, top up with a few μ l of solvent

Example 3 (20 ml)	
Grinding balls	approx. 1/4 of the glass vial with 3 mm grinding balls (stainless steel, zirconium oxide, agate)
Sample material/ Mixture of reactants	50 % filling volume of the vial, top up with a few μ l of solvent

8.1.1 Speed limits

Due to the high energy input of the device, strong forces act on the glass vials. The maximum speed specifications must be adhered to in order to prevent any damage to the adapter and the vials.

Device	Maximum speed	
	Adapter for 24 x 1.5 ml glass vials	Adapter for 7 x 20 ml glass vials
PM 100	550 rpm	350 rpm
PM 300	500 rpm	300 rpm
PM 400	400 rpm	250 rpm

8.1.2 Energy input

The energy input of the device to the glass vials in the adapter differs depending on the arrangement of the openings on the inner or outer diameter. The force applied to the inner diameter is comparable with 50 - 125 ml grinding jars. The force applied to the outer diameter is comparable with 250 - 500 ml grinding jars.

Green: Inner diameter, 50 - 125 ml grinding jars

Red: Outer diameter, 250 - 500 ml grinding jars

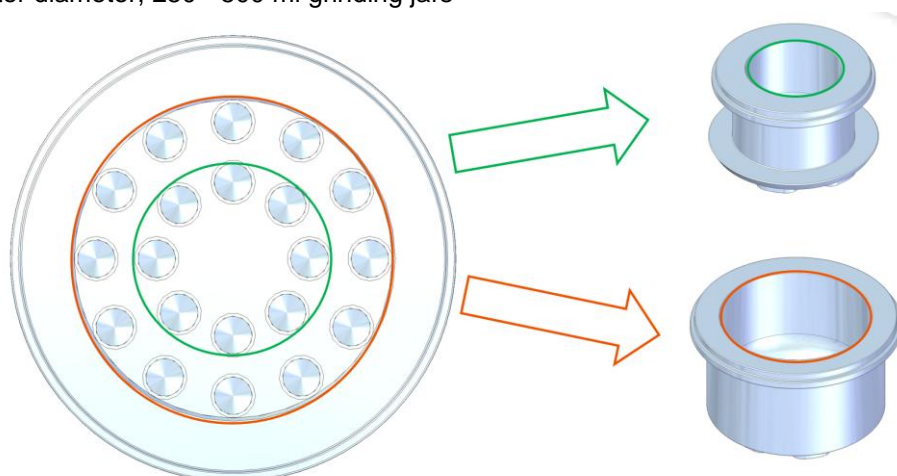

Fig. 38: Energy input as a function of diameter

9 Cleaning, Wear and Maintenance

WARNING

Risk of a fatal electric shock

- An electric shock can cause injuries in the form of burns and cardiac arrhythmia, respiratory arrest or cardiac arrest.
- **Do not clean the blender under running water. Use only a cloth dampened with water.**
- **Disconnect the power supply plug before cleaning the blender.**

WARNING

The device must always be switched off and disconnected from the mains before any interventions for cleaning or servicing purposes.

W0012

9.1 Maintenance

9.1.1 Servicing the closing pin

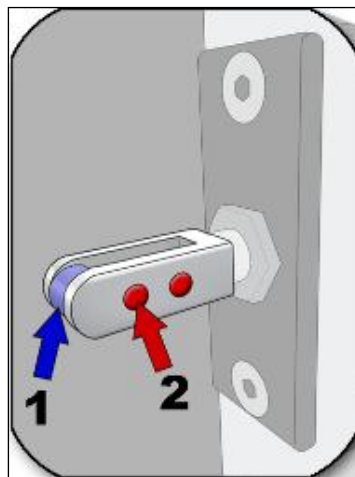

Fig. 39: Servicing the closing pin

To ensure the operational safety of the equipment, the following servicing work should be performed from time to time and at least once a month:

- Check the roller (1) on the closing pin to ensure it can move freely, and oil where necessary, e.g. using sewing machine oil.
- Clean the magnets (2) on the closing pin.

The smooth running of the roller (1) on the closing pin is the prerequisite for the safe closing of the housing lid.

9.1.2 Servicing the clamping unit

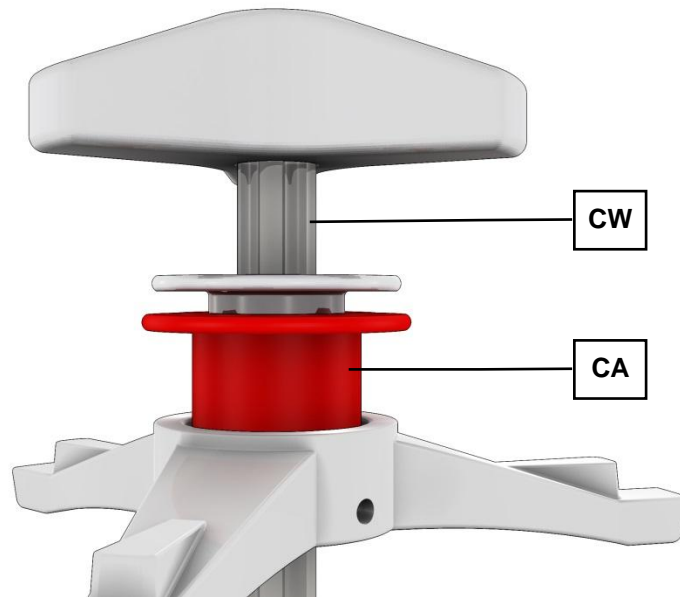

Fig. 40: Servicing the clamping unit

- Check that the threaded spindle (**CW**) and locking sleeve (**CA**) can move freely.
- In most cases a drop of oil will help.

The smooth running of the threaded spindle and locking sleeve is the prerequisite for the secure clamping of the grinding jars.

Locking sleeves which do not slide down automatically through spring force cannot reliably prevent the threaded spindle from coming loose. The grinding jars may be ejected.

Wear to the bases of the clamping unit

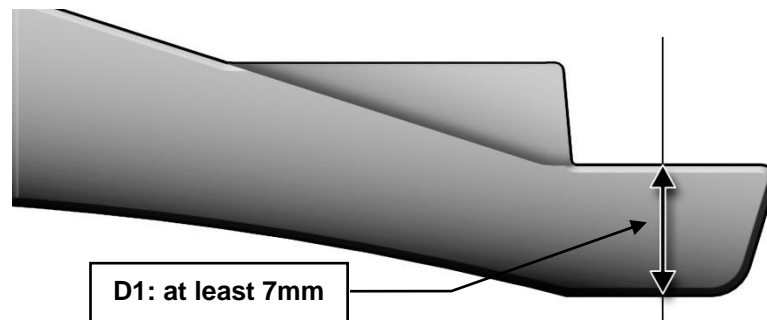

Fig. 41: Wear to the bases of the clamping unit

- Check the thickness (**D1**) of the three lead frame bases regularly for wear (at least monthly).
- The thickness (**D1**) of the three lead frame bases must not be less than 7mm.
- Operational safety can no longer be guaranteed if the thickness falls below this level (**D1**). The grinding jars may be ejected.

9.1.3 Rubber washer on the pressure plate

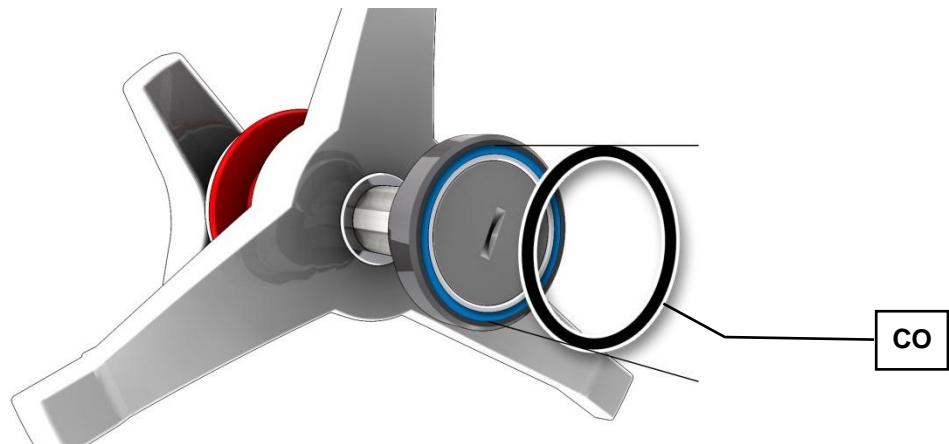

Fig. 42: Rubber washer on the pressure plate

- Check the O-ring (**CO**) on the pressure plate regularly for wear and to ensure it is secure.

9.1.4 Wear to latching bracket

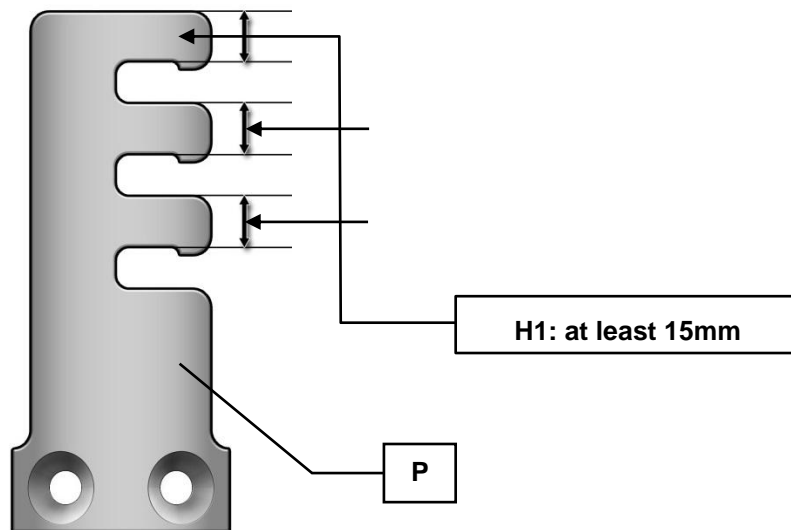

Fig. 43: Wear to the latching bracket

- Check the thickness (**H1**) of the 9 latching brackets (**P**) regularly for wear (at least monthly).
- The thickness (**H1**) of the 9 latching brackets (**P**) must not be less than 15mm.
- Operational safety can no longer be guaranteed if the thickness falls below this level (**H1**). The grinding jars may be ejected.

9.2 Return for Service and Maintenance



Fig. 44: Returned goods dispatch note

RETSCH devices and accessories can only be accepted for repair, maintenance or calibration if the returned goods despatch note has been correctly completed in full.

- When returning a device, attach the returned goods dispatch note to the outside of the packaging.

In order to eliminate any health risk to our employees, we reserve the right to refuse acceptance and to return the respective delivery at the expense of the sender.

10 Disposal

Please observe the respective statutory requirements with respect to disposal.

Information on disposal of electrical and electronic machines in the European Community.

Within the European Community the disposal of electrically operated devices is regulated by national provisions that are based on the EU Directive 2002/96/EC on Waste Electrical and Electronic Equipment (WEEE).

Accordingly, all machines supplied after 13.08.2005 in the business-to-business area to which this product is classified, may no longer be disposed of with municipal or household waste. To document this they have the following label:

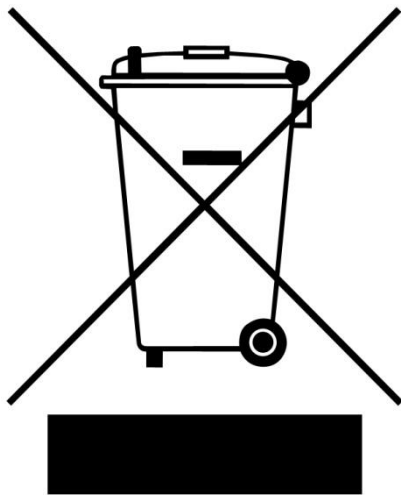

Fig. 45: Disposal label

Since the disposal regulations within the EU may differ from country to country we would request you to consult your supplier.

11 Index

>

>Mains connection..... 14

1

16A..... 20

A

Acoustic warning signal 53

Adapter 56

adapter for 24 x 1.5 ml glass vials 56

adapter for 7 x 20 ml glass vials 56

Adjustment options using the display menu 48

Agate..... 37

all current sensitive 14

all current sensitive 14

Ambient temperature 13

Amperage 13

Anti-rotation device 41

Anti-rotation device 41

Automatic lid closing 22

Automatic opening 53

B

Balancing 33, 34

 additional weight 34

Ball

 quantity 38

 sizes 38

Ball filling..... 38

Bar code 13

Basic settings..... 51, 53

Brightness..... 53

C

Capacity 13

CE marking 13

Ceramic insert..... 46

Change program 52

Changes 7

Clamping mechanism

 opening 36

Clamping unit

 servicing 60

 wear..... 60

Cleaning..... 59

Cleaning the grinding jars 43

Clearance distance 22

Close-up of the grinding chamber 24

Closing pin 28

 servicing 59

Confirmation 11

Connection cable 14, 20

Continuous sound level 21

Copyright 7

creating interface connection..... 15

D

Date..... 53

Decrease of sample volume during grinding
 process 38

Degree of protection 21

Delete program 52

Description 26, 27, 47

Device

 closing 28

 open..... 27

Device designation..... 13

Dimensions 22

DIN 45635-31-01-KL3..... 21

Direct access to the language menu 48

Direction reversal 51

Display and operation 47

Display unit – operation of the device..... 47

Disposal 63

Disposal label..... 13, 63

E

Electrical connection 14, 20

EMC Directive 14

Emergency release 29

 key storage..... 28

 storage 28

Emergency unlocking..... 28

Emissions..... 21

Energy input..... 58

Equivalent sound pressure level..... 21

Error code 55

Error messages..... 55

Errors 55

Explanations of the safety instructions 8

External fuse 14, 20

F

Fault messages..... 55

Feed grain size 20

Feed sizes..... 38

Flat wooden stick 42

Free-force compensation sockets..... 17

Frequency converter 14

Function 26, 27, 47

Function of the locking sleeve 32

Fuse strength 13

Fuse type 13

G

General safety instructions 9

 glas vial 56

 Grinding aid..... 46

 Grinding chamber inspection 37

 Grinding jar

 filling level..... 38

 identification 42

inserting.....	30	Overview Table of the Operating Elements and	
with safety closure device	46	the Display.....	27
Grinding jar cleaning.....	43	Overview table of the parts of the device.....	26
Grinding jar selection	37	P	
Grinding jar volume.....	38	Packaging	12
Grinding time	51	Part number	13
Gripping flanges.....	41	Pause time	51
H		Power	37
Handling grinding jars	40	Power consumption	20
I		Power failure	29, 37
Increase of sample volume during grinding		Power failure during grinding.....	37
process.....	38	Power version	13
Installation.....	12	Pressure plate.....	61
Installation height.....	13, 18	Prising open	42
Installation of the device	13, 18	Program 01 to 10.....	50
Installation site		Programme mode	52
conditions	13	property damage.....	8
Installing additional equipment	56	Protective earth.....	14
Interval	51	Protective equipment.....	22
IP20.....	21	Q	
L		Quantity	
Latching bracket		ball.....	38
wear.....	61	R	
Lid closing.....	22	Rated power.....	20
Lid closing mechanism	28	Receptacle volume	20
Locking sleeve	36	Regulations for the place of installation.....	14, 20
LpAeq.....	21	Releasing the grinding jar clamping mechanism	35
M		Remaining grinding time	37
Machine type designation.....	19	Removing the O-ring.....	43
Mains connection.....	20	Repair	10
Mains frequency	13	Required floor space.....	22
Maintenance	59	Residual current protection device	14
Manual mode.....	51	Return	
Manual operation.....	50	for service and maintenance	62
Manufacturer's address	13	Return goods dispatch note.....	62
Measurement conditions.....	21	Rubber washer.....	61
Menu structure.....	50	S	
Messages		safety closure device	46
errors.....	55	Safety locking device	44
Moderate or mild injury	8	Safety notice	54
N		Safety warnings	8
Noise levels	21	Sample material	37
Noise measurement.....	21	Sample quantity	38
Nominal volume	37	Sample volumes	38
Notes on the manual.....	7	Save parameters.....	52
Number of grinding stations.....	20	Selection bar	48
O		Serial number.....	13
Opening aid for the clamping unit.....	36	serious injury.....	8
Operating elements and displays	27	Service	53
Operating hours	53	Service Address.....	10
Operating modes	50	Set language.....	53
Operating software version.....	54	shielded cable	14
Operating the device.....	23	Sintered corundum.....	37
Operation	15, 47	Software version of display	53
		Software version of the controller	54
		Special steel.....	37
		Speed.....	51

Speed limits for the adapter.....	58	Use of the device for the intended purpose	19
Stainless steel.....	37	V	
Start in.....	52	Vacuum.....	42
Suppressor capacitor wiring	14	View of counterweight.....	25
Symbols in the Display Unit.....	47	View of the back of the device	25
T		View of the control panel	27
Target group	19	View of the front of the device	23
Target group	9	View of the menu on the display unit.....	47
Technical data	19	Views of the instrument.....	23
Temperature fluctuation and condensed water ..	12	W	
Time	53	Wear.....	31, 59
Transport	12, 15	Weight	13, 22
Transport lock		Wet grinding.....	46
removing from the device.....	16	with highly flammable materials	46
Transportation lock	15	Workplace-related equivalent sound pressure	
Tripping current.....	14	level	21
Tungsten carbide	37	Workplace-related equivalent sound pressure	
Type plate	13, 14, 20	level	21
description	13	wrong language	48
U		Y	
UKCA marking	13	Year of production.....	13
Ultrafine grinding.....	38	Z	
Unscrewing the transport lock from the transport		Zirconium oxide.....	37
pallet.....	16		
Update software.....	54		

PLANETARY BALL MILL

PM 100 | 20.540.xxxx

EU DECLARATION OF CONFORMITY

We, represented by the undersigned, hereby declare that the above device complies with the following directives and harmonised standards:

Machinery Directive 2006/42/EC

Applied standards, in particular:

DIN EN ISO 12100	Machine Safety - General Design Principles
DIN EN 61010-1	Safety Regulations for Electrical Measurement, Control, Regulation and Laboratory Devices

Electromagnetic compatibility 2014/30/EU (tested at 230 V, 50 Hz)

Applied standards, in particular:

EN 55011	Industrial, scientific and medical equipment - Radio-frequency disturbance characteristics - Limits and methods of measurement
DIN EN 61326-1	Electrical equipment for measurement, control and laboratory use - EMC requirements

Restriction of hazardous substances (RoHS) 2011/65/EU

Authorised person for compilation of the technical documentation:

Julia Kürten (Technical Documentation)

Furthermore, we declare that the relevant technical documentation for the above device has been prepared in accordance with Annex VII Part A of the Machinery Directive and we undertake to submit the documentation to the market surveillance authorities on request.

In the event of a modification of the device not agreed on by Retsch GmbH, as well as the use of non-approved spare parts or accessories, this declaration loses its validity.

Retsch GmbH

Haan, 09/2023



Dr. Frank Janetta, Head of Development



PLANETARY BALL MILL

PM 200 | 20.640.xxxx

EU DECLARATION OF CONFORMITY

We, represented by the undersigned, hereby declare that the above device complies with the following directives and harmonised standards:

Machinery Directive 2006/42/EC

Applied standards, in particular:

DIN EN ISO 12100	Machine Safety - General Design Principles
DIN EN 61010-1	Safety Regulations for Electrical Measurement, Control, Regulation and Laboratory Devices

Electromagnetic compatibility 2014/30/EU (tested at 230 V, 50 Hz)

Applied standards, in particular:

EN 55011	Industrial, scientific and medical equipment - Radio-frequency disturbance characteristics - Limits and methods of measurement
DIN EN 61326-1	Electrical equipment for measurement, control and laboratory use - EMC requirements

Restriction of hazardous substances (RoHS) 2011/65/EU

Authorised person for compilation of the technical documentation:

Julia Kürten (Technical Documentation)

Furthermore, we declare that the relevant technical documentation for the above device has been prepared in accordance with Annex VII Part A of the Machinery Directive and we undertake to submit the documentation to the market surveillance authorities on request.

In the event of a modification of the device not agreed on by Retsch GmbH, as well as the use of non-approved spare parts or accessories, this declaration loses its validity.

Retsch GmbH

Haan, 09/2023



Dr. Frank Janetta, Head of Development





Copyright

© Copyright by
Retsch GmbH
Retsch-Allee 1-5
42781 Haan
Germany