

# Manual

## Jaw Crusher BB 400

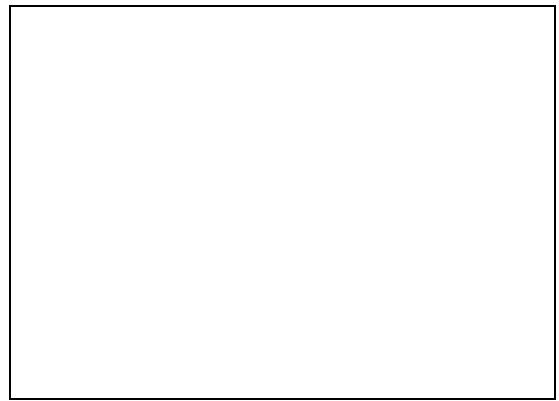

Translation

**Retsch**<sup>®</sup>

**Copyright**

© Copyright by  
Retsch GmbH  
Retsch-Allee 1-5  
42781 Haan  
Germany

## Table of Contents

<b>1</b>	<b>Notes on the Manual .....</b>	<b>6</b>
1.1	Disclaimer .....	6
1.2	Copyright.....	6
1.3	Explanation of signs and symbols .....	6
1.4	Explanations of the Safety Instructions .....	7
1.5	General Safety Instructions .....	8
1.6	Repairs.....	9
1.7	Responsibility of the operating company .....	10
1.8	Personnel qualification and target group of this manual .....	10
<b>2</b>	<b>Confirmation Form for the Managing Operator.....</b>	<b>11</b>
<b>3</b>	<b>Technical Data .....</b>	<b>12</b>
3.1	Protective Equipment.....	12
3.2	Mains connection.....	12
3.3	Gap width.....	12
3.4	Degree of Protection.....	12
3.5	Emissions.....	12
3.6	Electromagnetic Compatibility (EMC).....	13
3.7	Rated Power .....	13
3.8	Pre-fuse .....	13
3.9	Dimensions and Weight.....	13
3.10	Required Floor Space.....	13
3.11	Feed Grain Size.....	14
3.12	Grinding chamber volume.....	14
3.13	Degree of hardness of the sample material.....	14
3.14	Installation drawing.....	15
<b>4</b>	<b>Packaging, Transport and Installation .....</b>	<b>16</b>
4.1	Packaging .....	16
4.2	Transport.....	16
4.3	Temperature Fluctuations and Condensation .....	17
4.4	Conditions for the Installation Site .....	17
4.5	Electrical Connection .....	18
4.6	Type Plate Description.....	20
<b>5</b>	<b>First Commissioning.....</b>	<b>21</b>
5.1	Installation of the Device.....	21
5.2	Dust extraction.....	22
5.3	Lubricating the device when putting it into service for the first time .....	23
<b>6</b>	<b>Operating the Device .....</b>	<b>24</b>
6.1	Use of the Device for the Intended Purpose.....	24
6.2	Principle of Operation .....	25
6.3	Views of the Instrument .....	26
6.3.1	Front.....	26
6.3.2	Side view.....	28
6.4	Switching On / Off.....	29
6.5	Settings.....	30
6.5.1	Adjusting the gap width.....	30
6.5.2	Setting the gap width .....	31
6.6	Opening and Closing of the Device .....	32
6.7	Operation .....	33
6.7.1	Starting the crushing process .....	33
6.7.2	Adding sample material .....	33
6.7.3	Removing sample material after grinding .....	34
6.7.4	Stopping the crushing process .....	35
<b>7</b>	<b>Cleaning, Wear and Maintenance .....</b>	<b>36</b>

---

7.1	Cleaning.....	36
7.1.1	Removing and installing the feed hopper .....	37
7.1.2	Cleaning the feed hopper .....	37
7.2	Wear .....	38
7.2.1	Replacing the breaking jaws.....	38
7.2.2	Replacing the wearing plates.....	39
7.3	Maintenance .....	39
7.3.1	Lubricating the device .....	39
7.3.2	Checking the limit switch .....	40
7.4	Return for Service and Maintenance .....	41
<b>8</b>	<b>Accessories .....</b>	<b>42</b>
<b>9</b>	<b>Disposal.....</b>	<b>43</b>
<b>10</b>	<b>Index .....</b>	<b>44</b>



# 1 Notes on the Manual

This Manual provides technical guidelines for the safe operation of the device. Read this Manual through carefully before installing, putting into service and operating the device. Reading and understanding this Manual is essential for handling the device safely and as intended.

This Manual does not contain any repair instructions. Please contact your supplier or contact Retsch GmbH directly if anything is unclear or you have questions about these guidelines or the device, or in the case of any faults or necessary repairs.

You can find further information about your device at <http://www.retsch.com> on the pages for the specific device concerned.

## Amendment status:

The document amendment 0002 of the "Jaw Crusher BB 400" manual has been prepared in accordance with the Machinery Directive 2006/42/EC.

## 1.1 Disclaimer

This Manual has been prepared with great care. We reserve the right to make technical changes. We assume no liability for personal injuries resulting from the failure to follow the safety information and warnings in this Manual. No liability will be assumed for damage to property resulting from the failure to follow the information in this Manual.

## 1.2 Copyright

This document or parts of it or its content may not be reproduced, distributed, edited or copied in any form without prior written permission of Retsch GmbH. Damage claims shall be asserted in the case of infringements.

## 1.3 Explanation of signs and symbols

In this document the following **signs and symbols** are being used:

①	Reference to a recommendation and/or an important information
→	Reference to a chapter, table or figure
⇒	Action instruction
Name	Software menu function
[Name]	Software button
<Name>	Software checkbox

## 1.4 Explanations of the Safety Instructions

The following **warnings** in this Manual warn of possible risks and damage:

 <b>DANGER</b>	<small>D1.0000</small>
<p><b>Risk of fatal injuries</b> Source of danger</p> <ul style="list-style-type: none"> <li>– Possible consequences if the danger is ignored.</li> <li>• <b>Instructions and information on how to avoid the risk.</b></li> </ul>	

**Fatal or serious injuries** may result if the “Danger” sign is disregarded. There is a **very high risk** of a life-threatening accident or lasting personal injury. The signal word  **DANGER** is additionally used in the running text or in instructions.

 <b>WARNING</b>	<small>W1.0000</small>
<p><b>Risk of life-threatening or serious injuries</b> Source of danger</p> <ul style="list-style-type: none"> <li>– Possible consequences if the danger is ignored.</li> <li>• <b>Instructions and information on how to avoid the risk.</b></li> </ul>	

**Life-threatening or serious injuries** may result if the “Warning” sign is disregarded. There is an **increased risk** of a serious accident or of a possibly fatal personal injury. The signal word  **WARNING** is additionally used in the running text or in instructions.

 <b>CAUTION</b>	<small>C1.0000</small>
<p><b>Risk of injuries</b> Source of danger</p> <ul style="list-style-type: none"> <li>– Possible consequences if the danger is ignored.</li> <li>• <b>Instructions and information on how to avoid the risk.</b></li> </ul>	

**Average to slight injuries** may result if the “Caution” sign is disregarded. There is an average or slight risk of an accident or personal injury. The signal word  **CAUTION** is additionally used in the running text or in instructions.

**NOTICE**

N1.0000

**Type of damage to property**

Source of the damage to property

- Possible consequences if the information is ignored.
- **Instructions and information on how to avoid the damage to property.**

**Damage to property** may result if the information is disregarded. The signal word **NOTICE** is additionally used in the running text or in instructions.

**1.5 General Safety Instructions**

**CAUTION**

C2.0002

**Risk of injury**

Lack of knowledge of the Manual

- The Manual contains all safety-related information. Disregarding the Manual can therefore lead to injuries.
- **Read the Manual carefully before operating the device.**



**Target group**

All those operating, cleaning or working with or on the device.

This device is a modern, powerful product from Retsch GmbH and has been developed in line with the state-of-the art. The device is safe to use when operated correctly and when following the instructions in this manual.

**Safety Officer:**

The operating company itself must ensure that people authorised to work on the device...

- have read and understood all regulations contained in the chapter on safety;
- are aware before they start work of all instructions and regulations for the target group related to the work;
- have easy access to the technical documentation for this device at all times;
- have been familiarised with the safe and correct handling of the device before starting work on it, by means of a verbal introduction by a competent person and/or using this technical documentation.

**CAUTION** Improper operation can lead to personal injuries and damage to property. The operating company itself is responsible for its own safety and that of its staff. The operating company itself is responsible for ensuring that no unauthorised persons have access to the device.

**CAUTION** People under the influence of intoxicating substances (medications, drugs, alcohol), fatigue or health disorders are not allowed to operate the device.

**CAUTION**

C3.0015

**Risk of injury**

Improper modifications to the device

- Improper modifications to the device can result in injuries.
- **Do not make any unauthorised changes to the device.**
- **Only use the spare parts and accessories approved by Retsch GmbH!**

**NOTICE**

N2.0012

**Changes to the device**

Improper modifications

- The conformity declared by Retsch GmbH with the European Directives will lose its validity.
- Any warranty claims will be terminated.
- **Do not make any modification to the device.**
- **Use spare parts and accessories that have been approved by Retsch GmbH exclusively.**



## 1.6 Repairs

This manual does not contain any repair instructions. For safety reasons, repairs may only be carried out by Retsch GmbH or an authorised representative or by qualified service technicians.

**In case of repair, please inform...**

- ...the Retsch GmbH representative in your country,
- ...your supplier, or
- ...Retsch GmbH directly.

**Service address:**

## 1.7 Responsibility of the operating company

The company operating the machine is responsible for ensuring that every person working with the machine has been given precise instructions on the basis of this manual (commissioning, operation, servicing). Training for operating staff must include the following points:

- Intended use of the machine
- Hazard areas
- Safety regulations
- The company must be satisfied that staff have the required qualifications
- General instructions and what to do in an emergency
- Applicable accident prevention regulations
- Personal protective clothing required
- Operation of the machine according to this manual
- Recognised, applicable rules governing health and safety

Involve BB 400 in your emergency planning:

- Integrate BB 400 in your operating instructions regulating conduct in emergency situations.
- Integrate BB 400 in your risk assessment in acc. with the German Ordinance on Industrial Safety and Health (BetrSichV) to prevent accidents during work processes.
- Consider fire-fighting measures, tackling the effects of leaking substances, possible radiation, rescuing people, first-aid measures.

## 1.8 Personnel qualification and target group of this manual

This manual is intended for trained assembly personnel , maintenance staff and users . Training must be provided in the language of the personnel concerned so that all instructions are understood. As such the following personnel qualifications are necessary:

<b>Assembly, commissioning, instruction, troubleshooting, servicing work, as described in this manual</b>	Skilled technical staff as well as external service providers who speak German and the language of the operating personnel. The usual skills communicated during training, e.g. as a plant fitter, mechatronics engineer or toolmaker, are prerequisites for the assembly, commissioning and troubleshooting of the machine. Employees must be able to manage all applicable mechanical tasks and be familiar with and have experience of dealing with these.
<b>Operation</b>	Education/training in accordance with the above section, responsibilities of trained employees.
<b>Servicing/repairs</b>	They must be experienced, trained professionals, familiar with requirements and guidelines.

## 2 Confirmation Form for the Managing Operator

This manual contains essential instructions for operating and maintaining the device which must be strictly observed. It is essential that they be read by the user and by the qualified staff responsible for the device before the device is commissioned. This manual must be available and accessible at the place of use at all times.

The user of the device herewith confirms to the managing operator (owner) that he has received sufficient instructions about the operation and maintenance of the system. The user has received the manual, has read and taken note of its contents and consequently has all the information required for safe operation and is sufficiently familiar with the device.

The managing operator should for legal protection have the user confirm the instruction about the operation of the device.

I have read and taken note of the contents of all chapters in this manual as well as all safety instructions and warnings.

**User**

-----  
Surname, first name (block letters)

-----  
Position in the company

-----  
Place, date and signature

**Managing operator or service technician**

-----  
Surname, first name (block letters)

-----  
Position in the company

-----  
Place, date and signature

### 3 Technical Data

**NOTICE** This device is not designed as a production machine and for continuous operation, but as a laboratory device, intended for single-shift intermittent periodic operation of 8 hours per day.

#### 3.1 Protective Equipment

- This device may only be put into service once the door has been closed and the collecting receptacle has been inserted in the base frame.
- A limit switch (L) behind the collecting receptacle prevents the device being started in an unsafe state.
- Pulling out the collection container initiates a category 1 stop of the shredding process. The power supply to the motor will be interrupted.
- The door can only be opened once the collecting receptacle has been removed.
- The motor protection switch turns the drive motor off if there is a blockage in the jaws.

#### 3.2 Mains connection

230 V, 50 Hz

230 V, 60 Hz

400 V, 50 Hz

400 V, 60 Hz

Mains voltage fluctuations +/- 10%

#### 3.3 Gap width

- Gap width: 0 to 30 mm

#### 3.4 Degree of Protection

- IP 55

#### 3.5 Emissions

**Noise levels:**

The noise levels are influenced by the properties of the sample material.

Example:

Feed material:	Marble pebbles (< 50 mm)
Gap width:	< 1 mm
Final particle size	< 4 mm
Grinding chamber filling level:	~ 65 %

Under these operating conditions, the workplace-related equivalent continuous sound level  $L_{eq} = 84.7$  dB(A).

**CAUTION**

C4.0020

**Failure to hear acoustic signals**

Loud noises during grinding

- It is possible that acoustic warning signals and voice communication cannot be heard.
- **When planning the acoustic signals in the working environment, the volume of noises arising during grinding should be taken into consideration. It may be possible to use additional visual signals.**

**CAUTION**

C5.0045

**Damage to hearing**

A high noise level may arise depending on the type of the material, the jaws used and the duration of grinding

- Excessive noise in terms of level and duration can cause impairments or lasting damage to hearing.
- **Suitable sound insulation measures must be provided or hearing protection worn.**



### 3.6 Electromagnetic Compatibility (EMC)

- EMC class in accordance with DIN EN 55011: A

### 3.7 Rated Power

7 000 VA, 3 ~

### 3.8 Pre-fuse

20 A

### 3.9 Dimensions and Weight

- Height: ~1,399 mm
- Width: ~ 695 mm
- Depth: ~ 719 mm
- Weight: ~ 400 kg

### 3.10 Required Floor Space

- Width of floorspace: 695 mm
- Depth of floorspace: 719 mm

No safety distance is necessary! To improve operability, you should plan to leave a space of around 50 cm to the left of the machine.

**Location requirements :**

This floor-mounted device must be placed on a level, firm base.

### 3.11 Feed Grain Size

- Feed size: < 220 x 90 mm
- Final fineness: < 2 mm

The feed size depends on the sample material.

### 3.12 Grinding chamber volume

~ 2 160 ml

### 3.13 Degree of hardness of the sample material

The degree of hardness of the sample material should be above 3 on the Mohs' scale to achieve effective grinding. The degree jaws should be harder than the sample material to prevent increased wear on the jaws.

### 3.14 Installation drawing

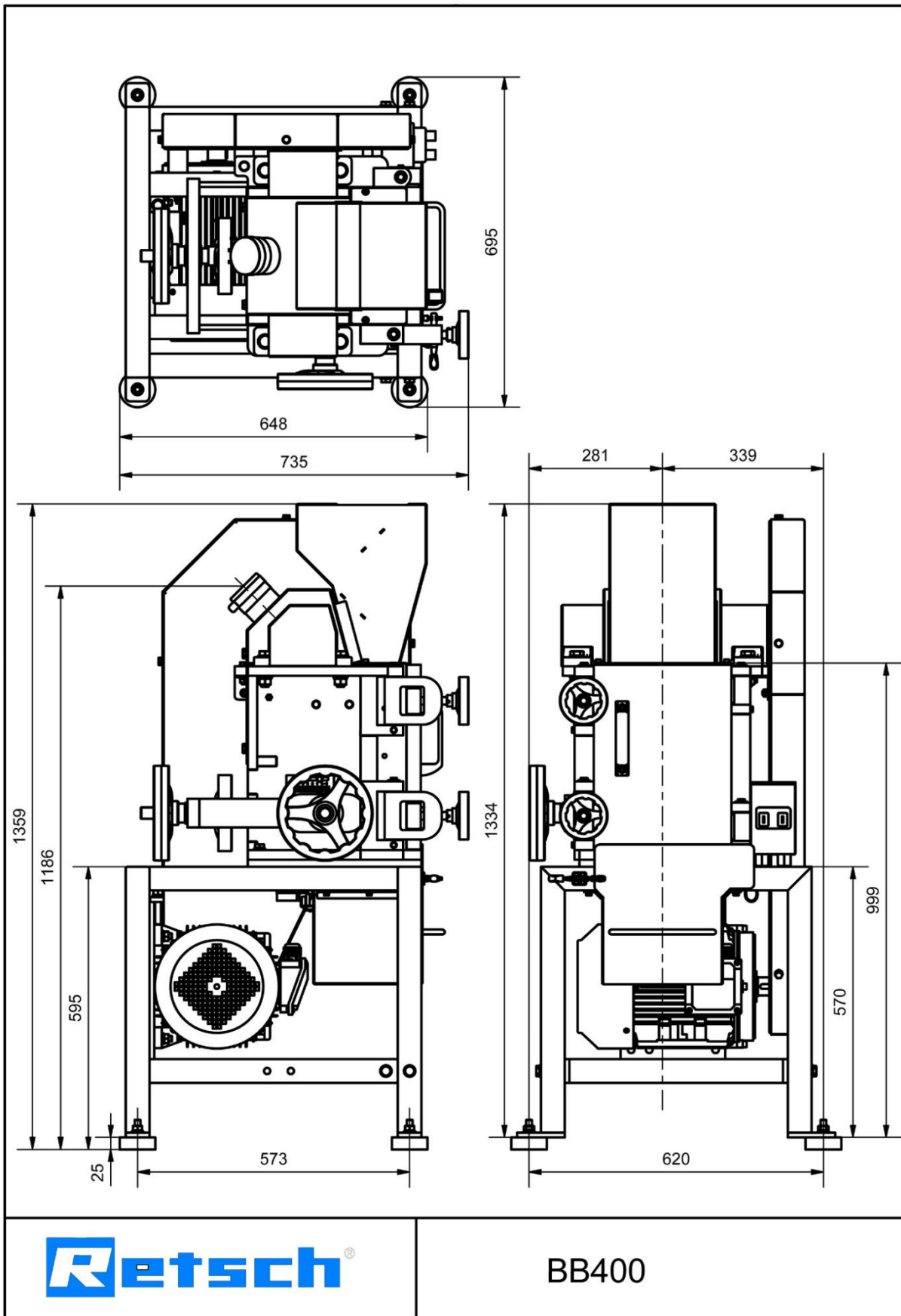

## 4 Packaging, Transport and Installation

### 4.1 Packaging

The packaging has been adapted to the mode of transport. It complies with the generally applicable packaging guidelines.

#### NOTICE

N3.0001

##### Complaint or return

Keeping the packaging

- Inadequate packaging and insufficient securing of the device can jeopardise the warranty claim in the event of a complaint or return.
- **Keep the packaging for the duration of the warranty period.**

### 4.2 Transport

#### DANGER

D2.0001

##### Serious personal injury

Suspended loads

- If dropped, the great weight of the device would result in serious injuries or death.
- **People must never stand below suspended loads!**



#### NOTICE

N4.0017

##### Damage to components

Transport

- Mechanical or electronic components may be damaged during transport.
- **The device must not be knocked, shaken or thrown during transport.**

#### NOTICE

N5.0014

##### Complaints

Incomplete delivery or transport damage

- The forwarding agent and Retsch GmbH must be notified immediately in the event of transport damage. It is otherwise possible that subsequent complaints will not be recognised.
- **Please check the delivery on receipt of the device for its completeness and intactness.**
- **Notify your forwarding agent and Retsch GmbH within 24 hours.**

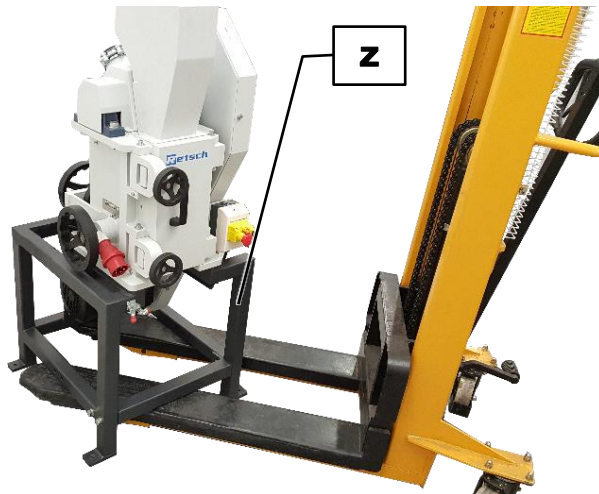



Fig. 1: Transporting with forklift

<b>⚠ WARNING</b>	W2.0011
<b>Serious personal injury</b> Load too heavy	
<ul style="list-style-type: none"> <li>– The device is extremely heavy, weighing 395 kg, which can lead to serious personal injury when it is lifted.</li> <li>• <b>The device may only be lifted and transported using lifting gear!</b></li> </ul>	
	

**⚠ CAUTION** Only use suitable lifting gear that has been approved for the weight of the device.

The BB 400 has a base frame (Z) using which the device can be lifted and transported with the help of lifting gear.

⇒ Move lifting gear such as a forklift under the base frame (Z).

⇒ Slowly lift the device using the lifting gear and stabilise it to prevent it from toppling over.

### 4.3 Temperature Fluctuations and Condensation

<b>NOTICE</b>	N6.0016
<b>Damaged components due to condensation</b> Temperature fluctuations	
<ul style="list-style-type: none"> <li>– The device may be exposed to substantial fluctuations in temperature during transport. The ensuing condensation can damage electronic components.</li> <li>• <b>Wait until the device has acclimatised before putting it into service.</b></li> </ul>	

**Temporary storage:**

Also in case of an interim storage the device must be stored dry and within the specified ambient temperature range.

### 4.4 Conditions for the Installation Site

- Installation height: max. 2 000 m above sea level
- Ambient temperature: 5 °C – 40 °C

**NOTICE**

N7.0021

**Ambient temperature**

Temperatures outside the permitted range

- Electronic and mechanical components may be damaged.
- The performance data alter to an unknown extent.
- **Do not exceed or fall below the permitted temperature range (5 °C to 40 °C ambient temperature) of the device.**
- Maximum relative humidity < 80 % (at ambient temperatures ≤ 31 °C)

For ambient temperatures  $U_T$  between 31 °C and 40 °C, the maximum relative humidity value  $L_F$  linearly decreases according to  $L_F = -(U_T - 55) / 0.3$ :

Ambient temperature	Max. rel. humidity
≤ 31 °C	80 %
33 °C	73.3 %
35 °C	66.7 %
37 °C	60 %
39 °C	53.3 %
40 °C	50 %

**NOTICE**

N8.0015

**Humidity**

High relative humidity

- Electronic and mechanical components may be damaged.
- The performance data alter to an unknown extent.
- **The relative humidity in the vicinity of the device should be kept as low as possible.**

**4.5 Electrical Connection**

**⚠ WARNING**

W3.0005

**Danger to life due to electric shock or fire**

Incorrect connection to the power supply may result in parts of the housing or cables being live and in fires starting.

- Serious injuries or death due to an electric shock.
- Serious injuries or death due to fires.
- **The device may only be connected by a qualified electrician.**



**NOTICE**

N9.0022

**Electrical connection**

Failure to observe the values on the type plate

- Electronic and mechanical components may be damaged.
- **Connect the device only to a mains supply matching the values on the type plate.**

**⚠ WARNING** When connecting the power cable to the mains supply, use an external fuse that complies with the regulations applicable to the place of installation.

- Information about the required voltage and frequency of the device can be found on the type plate.
- The listed values must agree with the existing mains supply.
- The device may only be connected to the power supply using the connection cable supplied.
- The circuit breaker at the installation site for connecting the mains cable to the mains should be suitable for higher inrush currents. It is recommended to use a type C circuit breaker or a Neozed or NH type fuse. The rated current of the fuse can be found on the rating plate or in the technical data.

### NOTICE

N10.0005

#### Electrical connection

Wrong direction of rotation on drive motor

- Electronic and mechanical components may be damaged.
- Insufficient grinding of the sample material.
- **Before putting into operation for the first time, check whether the direction of rotation of the motor (fan direction of rotation) complies with the direction arrow on the belt cover.**

**4.6 Type Plate Description**

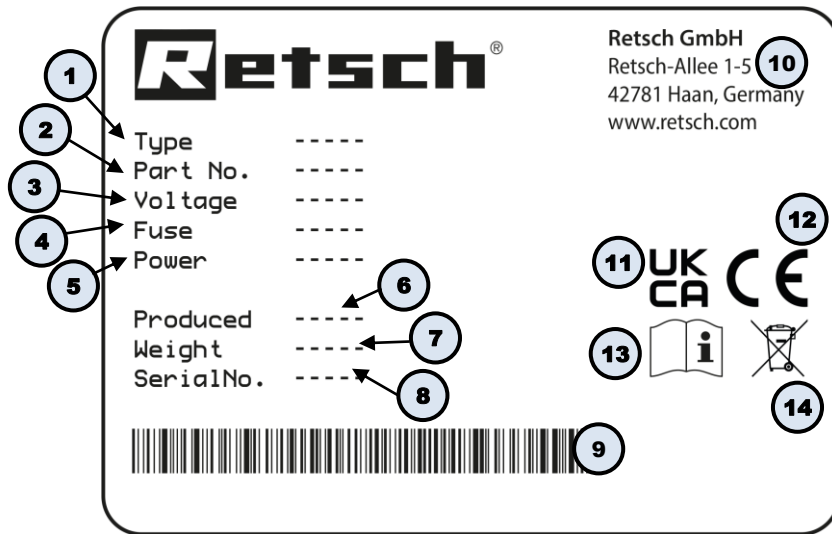

**Fig. 2:** Type plate

- 1 Device designation
- 2 Part number
- 3 Power version, Mains frequency
- 4 Fuse type and fuse strength
- 5 Capacity, Amperage
- 6 Year of production
- 7 Weight
- 8 Serial number
- 9 Bar code
- 10 Manufacturer's address
- 11 UKCA marking
- 12 CE marking
- 13 Safety warning: Read the manual
- 14 Disposal label

① In the case of queries please provide the device designation (1) or part number (2), as well as the serial number (8) of the device.

## 5 First Commissioning

**⚠ WARNING** W4.0002

**Danger to life through electric shock**  
 Damaged power cable

- Operating the device with a damaged power cable or plug can lead to life-threatening injuries caused by an electric shock.
- **Before operating the device, check the power cable and plug for damage.**
- **Never operate the device with damaged power cable or plug!**



**⚠ WARNING** W5.0004

**Danger to life due to electric shock**  
 Electrically conductive parts of the housing due to contact with live cables inside the housing

- An electric shock can result in burns, cardiac arrhythmia, respiratory arrest and cardiac arrest.
- **Always operate the device using a mains socket protected by a residual current circuit breaker (RCCB).**



**NOTICE** N11.0002

**Setting up the device**  
 Disconnecting the device from the mains

- A separation of the device from the mains must be possible at any time.
- **Set up the device in such a way, that the connection for the power cable is always easily accessible.**

**NOTICE** N12.0004

**Setting up the device**  
 Vibrations during operation

- Depending on the operating mode of the device, slight vibrations may occur.
- **Set up the device only on a vibration-free, plane and stable surface.**

### 5.1 Installation of the Device



Fig. 3: Securing on the transport pallet

- On delivery, the device is screwed onto the transport pallet.
- ⇒ Remove the four hex screws (**SC**) from the transport pallet.
  - ⇒ Using a forklift, lift the BB 400 up.

- ⇒ Attach the four feet of the device provided (vibration absorbers) to the base frame.
- ⇒ Place the BB 400 onto the designated installation surface.

If the device is installed without the feet (vibration absorbers), it must be screwed to a level, firm base.

- ⇒ Screw the BB 400 to the base using four suitable hex screws.

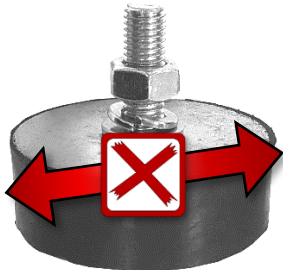

**Fig. 4:** Device feet: do not push or pull device

**NOTICE**

N13.0002

**Damage to the device feet**  
Pushing or pulling the device

- If the device is pushed or pulled across a surface, this can damage the device feet (vibration dampers).
- **Do not pull or push the device.**
- **Lift the device if you need to move it.**

**5.2 Dust extraction**

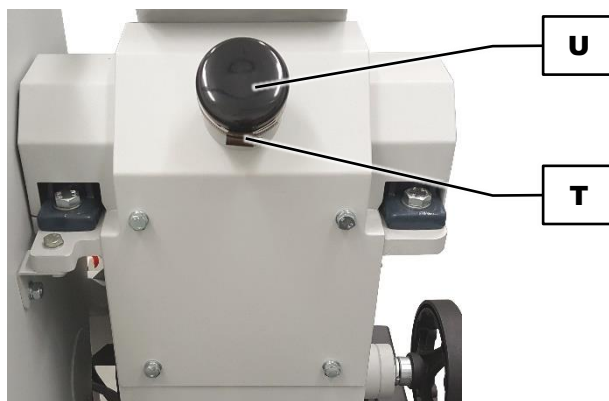
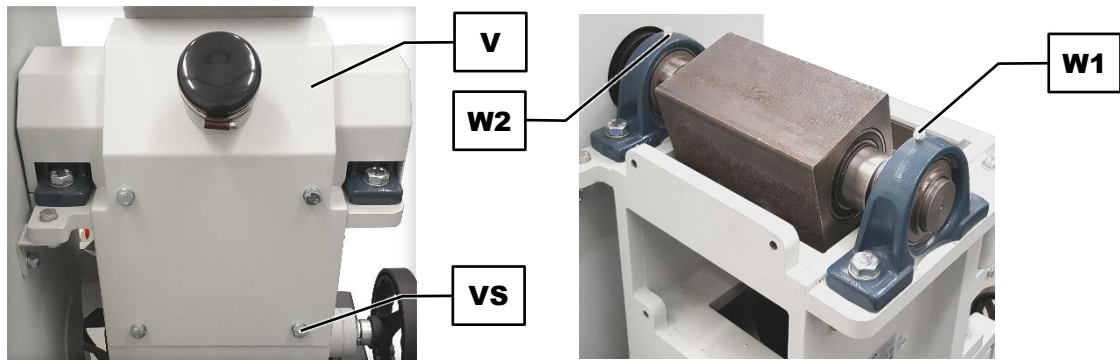

**Fig. 5:** Socket for dust extraction

**NOTICE** Dust can be extracted using an external dust extraction unit or industrial vacuum cleaner where necessary. The socket for dust extraction on the BB 400 has an outer diameter of 76 mm (inner diameter of 72 mm).

- ⇒ Loosen the hose clamp (**T**) on the dust extraction socket.
- ⇒ Pull the protective cover (**U**) from the socket.
- ⇒ Connect a suitable suction pipe (not included) to the dust extraction socket.
- ⇒ Attach the suction pipe to the socket using the hose clamp (**T**).

### 5.3 Lubricating the device when putting it into service for the first time



**Fig. 6:** Putting into service for the first time: lubrication points

**NOTICE** The BB 400 must be lubricated after **eight operating hours** when put into service for the first time . Use the supplied grease press that is filled with Shell Gadus S2 V220 2 for lubrication.

The following quantities of grease are required for the two lubrication points (**W1, W2**) on the device:

Lubrication point	Quantity (grams)	Operating state
<b>W1</b>	7	Standstill
<b>W2</b>	7	Standstill

**Lubricating the lubrication points (W1, W2) under the cover**

- ⇒ Switch the BB 400 off.
- ⇒ Disconnect the BB 400 from the power supply and secure to prevent it restarting.
- ⇒ Remove the feed hopper.
- ⇒ Unscrew the four M10x25 hex screws (**VS**) on the cover (**V**) at the back of the device.
- ⇒ Remove the cover (**V**) from the device.
- ⇒ Place the grease press on the lubrication points in turn (**W1, W2**) and press the right amount of grease into the respective lubrication point.
- ⇒ Place the cover (**V**) back onto the device.
- ⇒ Secure the cover (**V**) using the four M10x25 hex screws (**VS**).
- ⇒ Assemble the feed hopper on the device.

## 6 Operating the Device

### 6.1 Use of the Device for the Intended Purpose

**⚠ CAUTION**

C6.0005

**Risk of injury**

Potentially explosive atmosphere

- The device is not suitable for use in potentially explosive atmospheres. Operating the device in a potentially explosive atmosphere can lead to injuries caused by an explosion or fire.
- **Never operate the device in a potentially explosive atmosphere!**

**⚠ CAUTION**

C7.0006

**Risk of injury**

Sample material that is harmful to health

- Sample material that is harmful to health can injure people (illness, contamination).
- **Use suitable extraction systems with sample material that is harmful to health.**
- **Use suitable personal protective equipment with sample material that is harmful to health.**
- **Take note of the safety data sheets for the sample material.**



**⚠ CAUTION**

C8.0010

**Risk of burns or poisoning**

Varying sample properties

- The properties and therefore also the chemical reactivity of the sample can change during the grinding process and can cause burns or poisoning as a result.
- **Do not process any substances in this device whose chemical reactivity is so changed by grinding that there is a risk of explosion or poisoning.**
- **Take note of the safety data sheets for the sample material.**



**⚠ CAUTION**

C9.0004

**Risk of injury**

Explosive or flammable samples

- Samples can explode or catch fire during the grinding process.
- **Do not use any samples in this device that carry a risk of explosion or fire.**
- **Take note of the safety data sheets for the sample material.**



**NOTICE**

N14.0007

**Range of application of the device**

Long-term operation

- This laboratory device has been designed for 8-hour single shift operation.
- **This device must not be used as a production machine or deployed in continuous operation.**

**NOTICE**

N15.0000

**Selection of suitable materials**

- You might be using unsuitable materials.
- **Use the manufacturer's application database to check whether your sample material is suitable for use.**

The Jaw Crusher BB 400 is suitable for coarse and preliminary grinding of medium-hard, hard, brittle and hard ductile materials such as basalt, building materials, ores, feldspar, glass, granite, ceramics, coal, coke, alloys, minerals, oxide ceramics, quartz, fireclay, slag, silicon, stone and cement clinker. The maximum feed size is 220 x 90 mm. The end fineness that can be achieved can be up to 2 mm and less depending on the breaking properties of the grinding material.

The BB 400 is ideal for preparing samples in the laboratory. Smaller quantities of sample can be ground in batches, while continuous operation is possible when processing larger quantities. Jaws made of three different materials enable them to be adapted to diverse sample properties (e.g. very hard materials) or for heavy metal-free grinding. Only breaking jaws from Retsch GmbH may be deployed.

In principle, the preliminary grinding of any hard and brittle materials with a degree of hardness greater than 3 on the Mohs' scale is possible. Preliminary grinding of moist, greasy material with a degree of hardness of less than 3 on the Mohs' scale is not possible because the compressive stress results in a tendency to produce compacting and caking in the crushing chamber.

Any other use is considered to be improper and can lead to damage to property and even to personal injuries.

## 6.2 Principle of Operation

The BB 400 is a robust and powerful forced-feed crusher. The feed material passes through the no-rebound hopper and enters the crushing chamber. Size reduction takes place in the wedge-shaped area between the fixed crushing arm and one moved by an eccentric drive shaft. The elliptical motion crushes the sample which is moved towards the crushing gap under gravity. As soon as the sample is smaller than the discharge gap width, it falls into a removable collector within the jaw crusher. The continuous gap width setting with scale ensures optimum size reduction in accordance with the set gap width.

### 6.3 Views of the Instrument

#### 6.3.1 Front

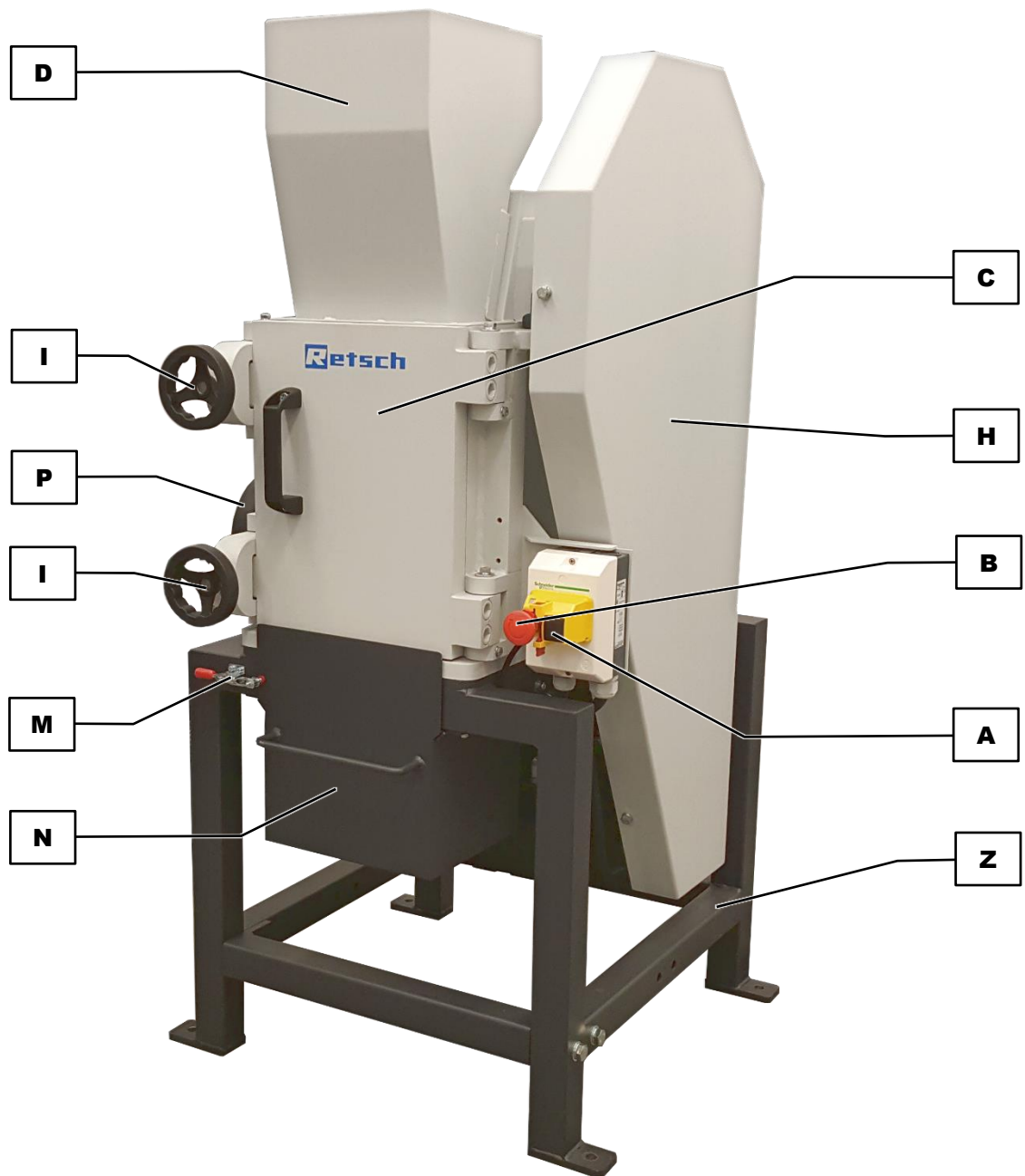

**Fig. 7:** Front view of the device

Element	Description	Function
<b>A</b>	ON switch	Switches the device on
<b>B</b>	OFF switch/emergency stop	Switches the device off
<b>C</b>	Door	For accessing the grinding chamber
<b>D</b>	Feed hopper	Hopper with contact protection for feeding the sample material
<b>F</b>	Lock nut	Locks the threaded spindle <b>G</b>
<b>G</b>	Threaded spindle	Changes the gap width
<b>H</b>	V-belt cover	Covers the V-belt on the drive
<b>I</b>	Door lock	Locks the door
<b>M</b>	Lock	Locks the collecting receptacle (drawer)
<b>N</b>	Collecting receptacle	Collecting receptacle (drawer) collects the ground sample material
<b>P</b>	Hand wheel clamp	Retains the set gap width
<b>Z</b>	Base frame	Base frame on the device

6.3.2 Side view

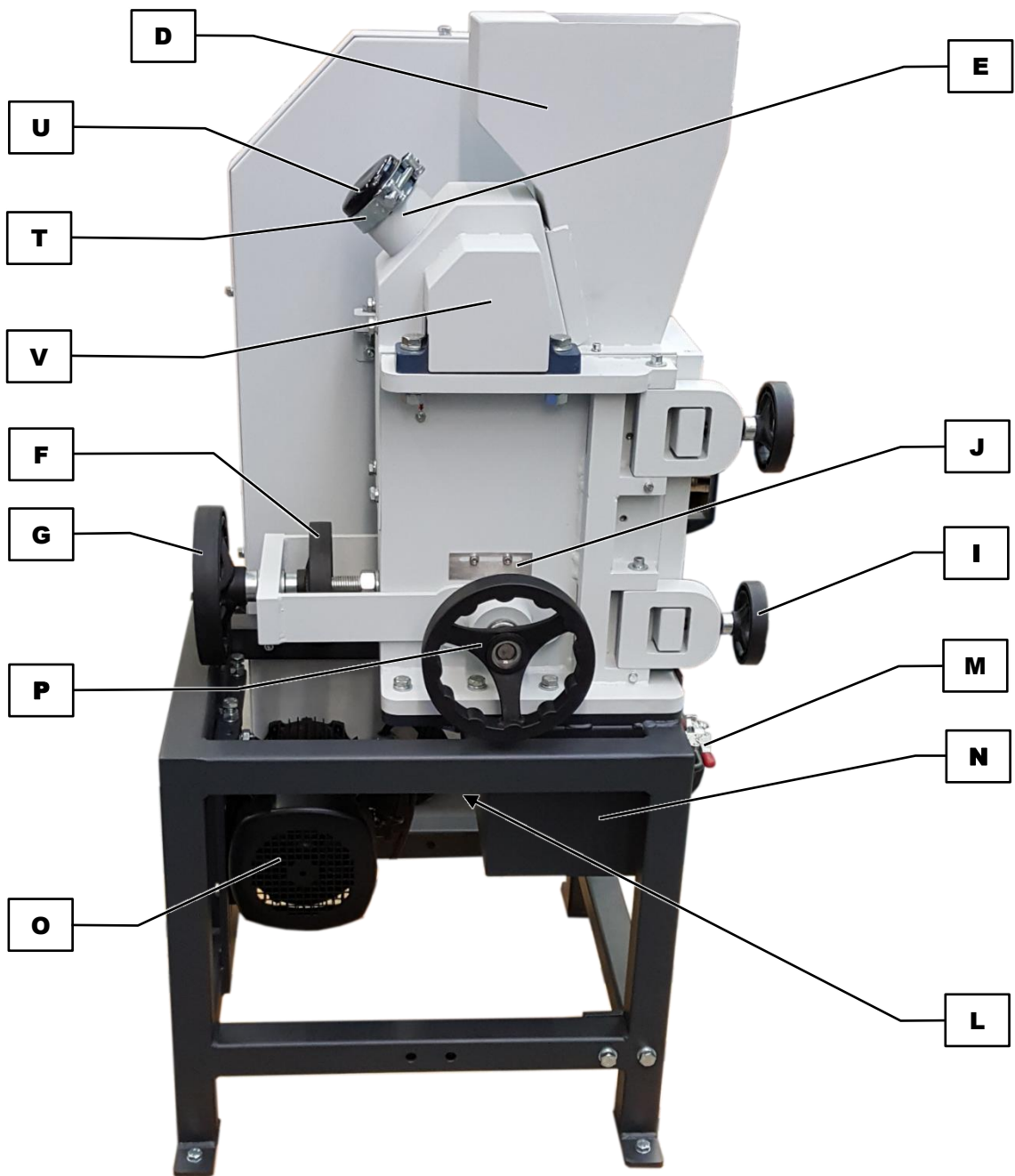

**Fig. 8:** Side view of the device

Element	Description	Function
<b>D</b>	Feed hopper	Hopper with contact protection for feeding the sample material
<b>E</b>	Dust extraction connection	Dust extraction during the grinding process possible
<b>F</b>	Lock nut	Locks the threaded spindle <b>G</b>
<b>G</b>	Threaded spindle	Changes the gap width
<b>I</b>	Door lock	Locks the door
<b>J</b>	Scale	Scale for setting the gap width
<b>K</b>	Pointer	Marks the gap width on the scale
<b>L</b>	Limit switch	Stops the drive when the drawer is opened
<b>M</b>	Lock	Locks the collecting receptacle (drawer)
<b>N</b>	Collecting receptacle	Collecting receptacle (drawer) collects the ground sample material
<b>O</b>	Drive motor	Device drive
<b>P</b>	Hand wheel clamp	Retains the set gap width
<b>T</b>	Hose clamp	Secures the cover <b>U</b> on the dust extractor
<b>U</b>	Cover	Cover of the dust extraction socket
<b>V</b>	Cover of lubrication points	Cover for lubrication points W1 and W2

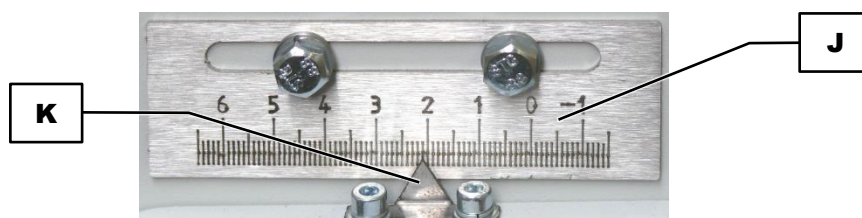

Fig. 9: Scale for adjusting the gap width

Element	Description	Function
<b>J</b>	Scale	Scale for adjusting the gap width
<b>K</b>	Pointer	Marks the gap width on the scale

## 6.4 Switching On / Off

In order to switch on the device, please proceed as follows:

- ⇒ Check whether the device is correctly connected to the power supply.
- ⇒ Release emergency stop switch (**B**) by turning it clockwise.
- ⇒ Start the device by pressing the adjacent ON-switch (**A**).
- ➔ The device has been switched on and immediately starts with the grinding process.

In order to switch off the device, please proceed as follows:

**NOTICE:** The device must not be switched off until there is no longer any sample material in the grinding chamber that needs to be grinded.

- ⇒ Switch off the device by pressing the emergency stop switch (**B**) which is located on the front side of the device.

→ The switch engages. The device has been switched off.

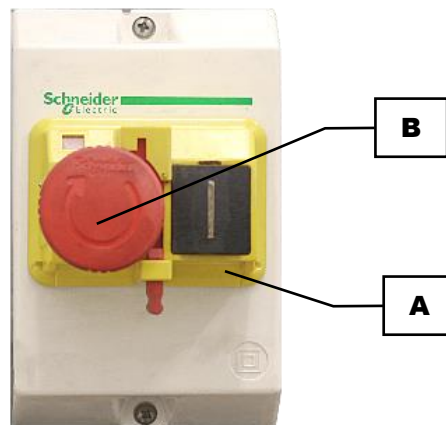

Fig. 3: Emergency stop switch

## 6.5 Settings

### 6.5.1 Adjusting the gap width

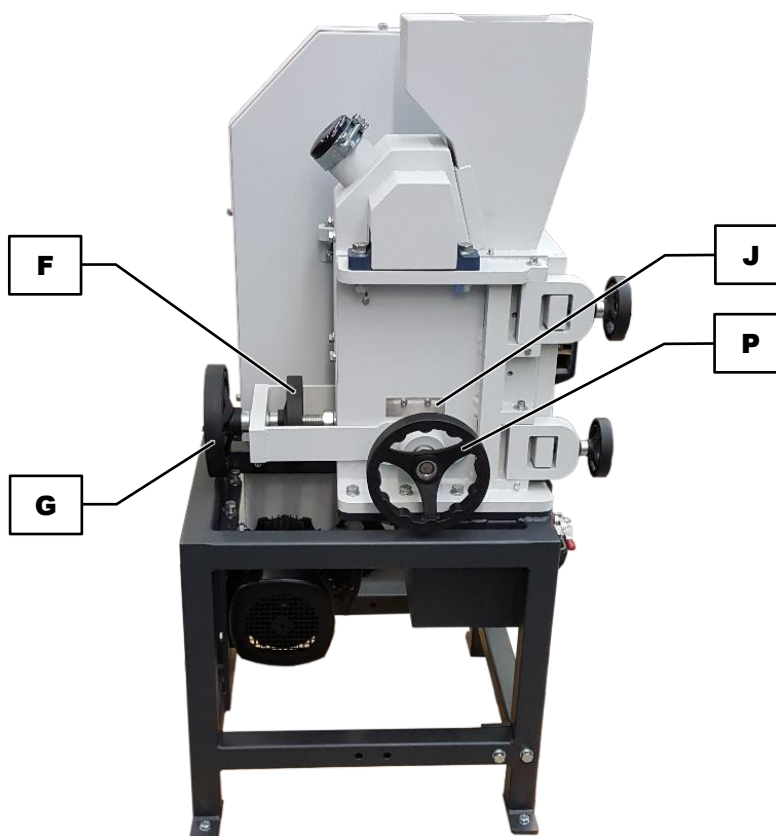

Fig. 10: Adjusting the gap width (zero position)

- ⇒ Start the unit (idle mode).
- ⇒ Unscrew the lock nuts (**F**) in a clockwise direction.
- ⇒ Unscrew the locating screw (**P**) in an anticlockwise direction.
- ⇒ Carefully twist the threaded spindle (**G**) to the right until it is just possible to hear the meeting of the two jaws.

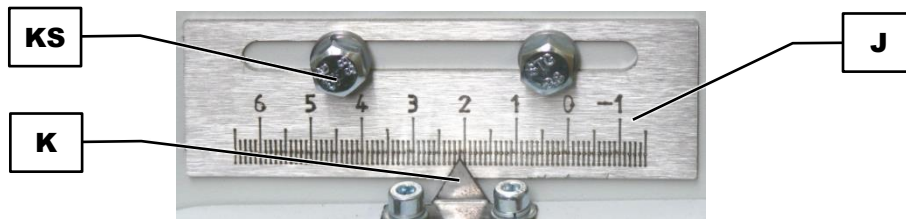

Fig. 11: Moving the scale

Move the scale (J) if the pointer (K) on the scale (J) is **not** on “0”:

- ⇒ Unscrew the two hex screws (KS).
- ⇒ Move the scale (J) sideways until the pointer is on zero.
- ⇒ Tighten the two hex screws (KS) again.
- ⇒ Then set the desired gap width for the next grinding process.

**NOTICE** Always set the gap width of the BB 400 to **more than 0 mm**. Where the minimum gap width is required, open the gap just wide enough for the meeting of the two jaws to no longer be audible.

Any blockage that arises can cause damage to the mechanical components.

### 6.5.2 Setting the gap width

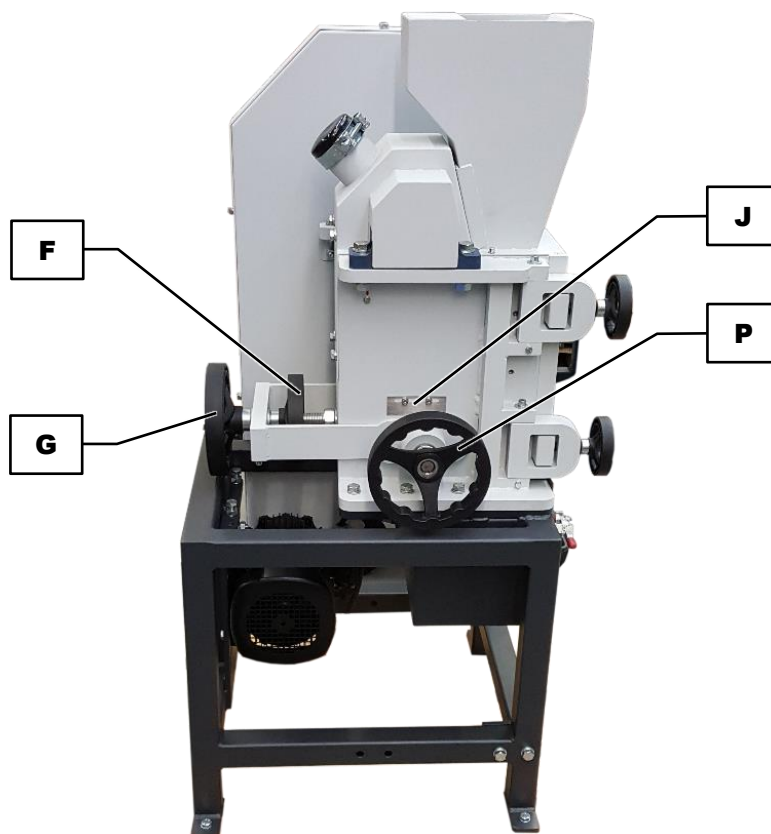
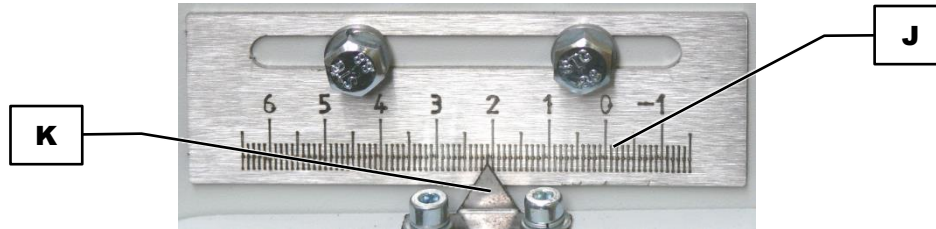

Fig. 12: Adjusting the gap width

- ⇒ Start the unit (idle mode).
- ⇒ Unscrew the lock nuts (F) in a clockwise direction.
- ⇒ Unscrew the locating screw (P) in an anticlockwise direction.
- ⇒ Reduce the gap: turn the threaded spindle (G) to the right.
- ⇒ Increase the gap: turn the threaded spindle (G) to the left.

The pointer (**K**) shows the approximate gap width on the scale (**J**).

**NOTICE** If the pointer (**K**) does not move when adjusting the gap width, the jaw has become stuck due to dirt. In this case you can release the jaw by twisting the lock nut (**F**) to the left.

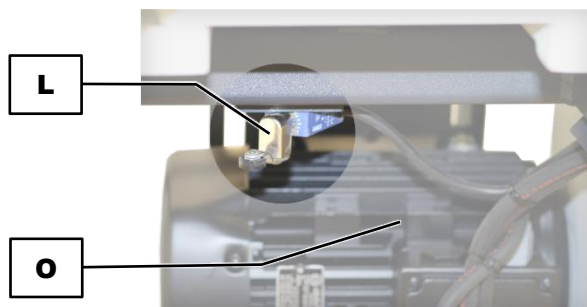

**Fig. 13:** Scale for adjusting the gap width

**NOTICE** The maximum gap width is 30 mm .

- ⇒ Tighten the lock nut (**F**) in an anticlockwise direction.
- ⇒ Tighten the locating screw (**P**) in a clockwise direction.

## 6.6 Opening and Closing of the Device



**Fig. 14:** Limit switch behind the collecting receptacle

**NOTICE** There is a limit switch (**L**) behind the collecting receptacle which stops the drive motor (**O**) for safety reasons when the collecting receptacle is removed.



**Fig. 15:** Opening and closing the door

### Opening the door

- ⇒ Pull the collecting receptacle (**N**) from the base frame (**Z**) and place it to one side.
- ⇒ Open the two hand wheels of the door lock (**I**) by turning to the left .

- ⇒ Fold back the two door clamps (**S**) to the side.
- ⇒ Open the door (**C**).

**Closing the door**

- ⇒ Close the door (**C**).
- ⇒ Fold back the two door clamps (**S**) to the door.
- ⇒ Close the two hand wheels of the door lock (**I**) by turning to the right.
- ⇒ Slide the collecting receptacle (**N**) into the base frame (**Z**).

## 6.7 Operation

### 6.7.1 Starting the crushing process

**NOTICE**

N16.0003

**Damage to mechanical components**

Overfilling the feed hopper and the grinding chamber

- Feeding too much sample material can result in increased wear to the jaws and wearing plates and to blockages.
- **Do not use the feed hopper for storing sample material.**
- **The grinding chamber should not be filled over 65%.**
- **Do not exceed the specified maximum feed size for the sample material.**
- **Fill larger and firmer sample material slowly and gradually into the feed hopper.**
- **If necessary, pre-grind larger and firmer sample material using a larger gap width.**

The purpose of the feed hopper (**D**) is to add the sample material to the grinding chamber, hold back sample material that splashes back and prevent anybody reaching into the grinding chamber.

Larger pieces of sample material should only be placed individually into the feed hopper (**D**). Observe the change in the grinding noise, and only add more sample material when there is a distinct reduction in the grinding noise.

### 6.7.2 Adding sample material

**CAUTION**

C10.0045

**Damage to hearing**

A high noise level may arise depending on the type of the material, the jaws used and the duration of grinding

- Excessive noise in terms of level and duration can cause impairments or lasting damage to hearing.
- **Suitable sound insulation measures must be provided or hearing protection worn.**



**NOTICE** Start the BB 400 before you begin adding sample material! The BB 400 can only be started when the door has been closed and the collecting receptacle inserted. The maximum feed size must not exceed **220 mm x 90 mm**.

- ⇒ **While the device is running**, fill the sample material slowly and continuously into the feed hopper (D). This guarantees more effective and faster grinding.
- ⇒ Depending on the properties of the sample material, the crushing chamber may not be filled more than 2/3 full, otherwise the jaws can become blocked and the motor protection switch turns the drive off. Continuous overfilling produces extreme wear on the wearing plates in the crushing chamber.
- ⇒ During the grinding process, pay attention to the quantity of sample material in the collecting receptacle (N). The collecting receptacle (N) must be emptied as soon as the filled quantity reaches 90% of its volume.

### 6.7.3 Removing sample material after grinding

**⚠ CAUTION**

C11.0005

**Burns**

Heating of the sample material during grinding

- Hot surfaces on the collecting receptacle or the grinding chamber can cause burns.
- Hot sample material in the collecting receptacle can cause burns.
- **Allow the hot sample material to cool down before removing the collecting receptacle and opening the door.**
- **Wear protective gloves.**



**⚠ CAUTION**

C12.0010

**Heavy collecting receptacle**

Depending on the density of the sample material or the filling level, the filled collecting receptacle may be very heavy.

- Due to its weight, a filled collecting receptacle can cause personal injuries when lifted out from the base frame.
- **As a general rule, always use both hands to pull the collecting receptacle out of the base frame.**
- **Two people should always remove a heavy collecting receptacle from the base frame.**
- **Wear safety shoes.**

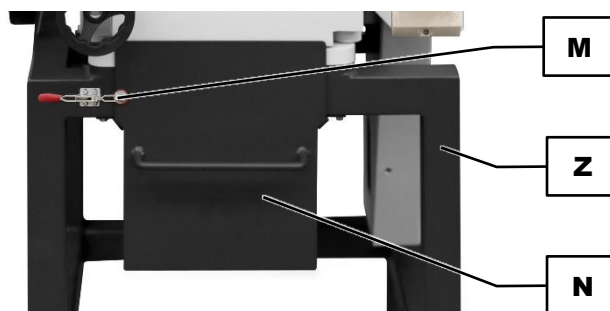

**Fig. 16:** Collecting receptacle

- ⇒ Switch the BB 400 off.
- ⇒ Open the lock (M) on the collecting receptacle (N).
- ⇒ Pull the collecting receptacle (N) from the base frame (Z).
- ⇒ Remove the ground sample material from the collecting receptacle (N).

- ① The BB 400 can be retrofitted for batch processing or continuous operation with a collecting hopper and a 30 l collecting receptacle which are available as optional [accessories](#).

**NOTICE**

N17.0004

**Damage to mechanical components**

Crusher blockage and the motor switching off

- Due to the size and geometry of the grinding chamber, blockages may occur when feeding a large quantity of big pieces of firmer sample material.
- If the device is not switched off promptly in the event of blockages, a motor protection switch turns the overloaded drive motor off.
- **Switch the device off immediately when there is a blockage, open the door and remove the sample material causing the blockage.**
- **Reduce the feed of sample material to the feed hopper.**
- **Fill larger and firmer sample material slowly and gradually into the feed hopper.**
- **If necessary, pre-grind larger and firmer sample material using a larger gap width**

**6.7.4 Stopping the crushing process**

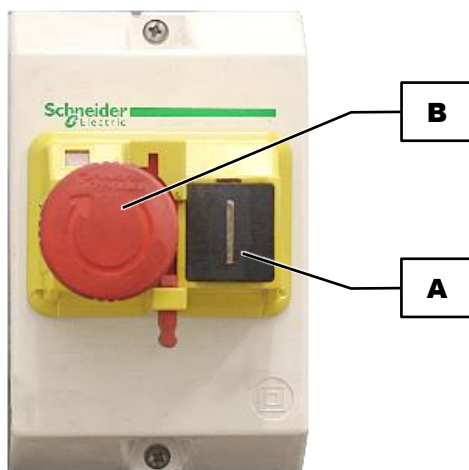

**Fig. 17:** Emergency stop switch

**NOTICE** The BB 400 may only be stopped when there is no longer any sample material in the crushing chamber. The jaws can otherwise block and mechanical components can be damaged.

- ⇒ Press the emergency stop switch (**B**) on the front of the device. The emergency stop switch (**B**) engages and prevents an unintentional restart.
- ⇒ Turn the emergency stop switch (**B**) to the right to unlock it in order to start the BB 400 again using the ON switch (**A**) .

## 7 Cleaning, Wear and Maintenance

### **⚠ CAUTION**

C13.0013

#### Risk of injury

Improper repairs

- Unauthorised and improper repairs can cause injuries.
- **Repairs to the device may only be carried out by the Retsch GmbH , an authorised representative or by qualified service technicians.**
- **Do not carry out any unauthorised or improper repairs to the device!**

### 7.1 Cleaning

### **⚠ WARNING**

W6.0003

#### Risk to life caused by an electric shock

Cleaning live parts with water

- Cleaning the device with water can lead to life-threatening injuries caused by an electric shock if the device has not been disconnected from the power supply.
- **Only carry out cleaning work on the device when it has been disconnected from the power supply.**
- **Use a cloth moistened with water for cleaning.**
- **Do not clean the device under running water!**



### **⚠ CAUTION**

C14.0031

#### Risk of injury

Cleaning with compressed air

- When using compressed air for cleaning purposes dust and remnant of the sample material can be flung around and injure eyes.
- **Always wear safety glasses when cleaning with compressed air.**
- **Observe the material safety data sheets of the sample material.**



### **NOTICE**

N18.0009

#### Damage to the housing and device

Use of organic solvents

- Organic solvents may damage plastic parts and the coating.
- **The use of organic solvents is not permitted.**

- ⇒ Clean the housing of the device with a damp cloth and if necessary, with a household cleaning agent. Pay attention that no water or cleaning agent enters the interior of the device.
- ⇒ Clean the grinding chamber and jaws using a brush, and vacuum the material residue released using an industrial vacuum cleaner.
- ⇒ The grinding chamber can alternatively be cleaned using compressed air.

### 7.1.1 Removing and installing the feed hopper

**WARNING**

W7.0003

**Serious personal injury**  
 Contact between moving jaws in the grinding chamber

- Accidentally reaching into the grinding chamber and between moving jaws can cause serious injuries to hands.
- **Always operate the device with the feed hopper installed.**

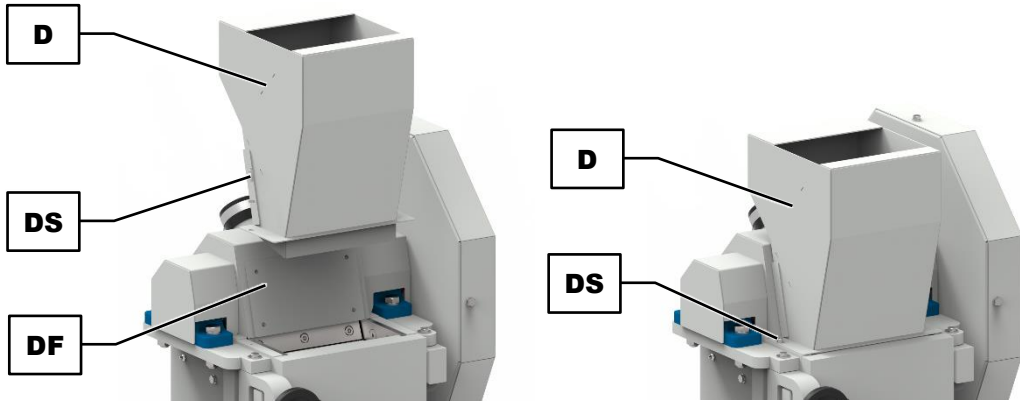

Fig. 18: Removing and assembling the feed hopper

**Removing the feed hopper**

- ⇒ Switch the BB 400 off.
- ⇒ Disconnect the BB 400 from the power supply and secure to prevent it restarting.
- ⇒ Unscrew the M6 Allen screw (DS).
- ⇒ Lift the feed hopper (D) up and out.

**Assembling the feed hopper**

- ⇒ Slide the feed hopper (D) downwards from above over the guide plate (DF).
- ⇒ Secure the feed hopper (D) using the M6 Allen screw (DS).

### 7.1.2 Cleaning the feed hopper

**WARNING**

W8.0003

**Serious personal injury**  
 Contact between moving jaws in the grinding chamber

- Accidentally reaching into the grinding chamber and between moving jaws can cause serious injuries to hands.
- **Always operate the device with the feed hopper installed.**

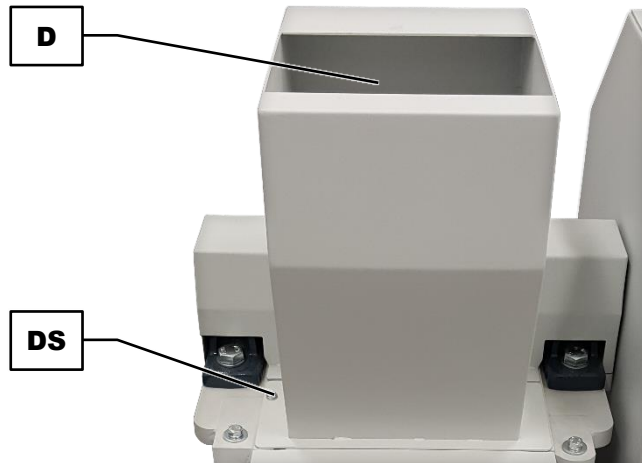

**Fig. 19:** Cleaning the feed hopper

- ⇒ Switch the BB 400 off.
- ⇒ Disconnect the BB 400 from the power supply and secure to prevent it restarting.
- ⇒ Unscrew the M6 Allen screw (**DS**).
- ⇒ Lift the feed hopper (**D**) up and out.
- ⇒ Clean the feed hopper (**D**) using compressed air.
- ⇒ The feed hopper (**D**) can additionally be wiped clean using a damp cloth and household detergent.
- ⇒ Place the feed hopper (**D**) back on the device and secure it using the M6 Allen screw (**DS**).

## 7.2 Wear

Jaws may become worn depending on the frequency of grinding operations and the quality of the sample material. The jaws (**Q**) and wearing plates (**R**) should be inspected for wear regularly and replaced where necessary.

### 7.2.1 Replacing the breaking jaws

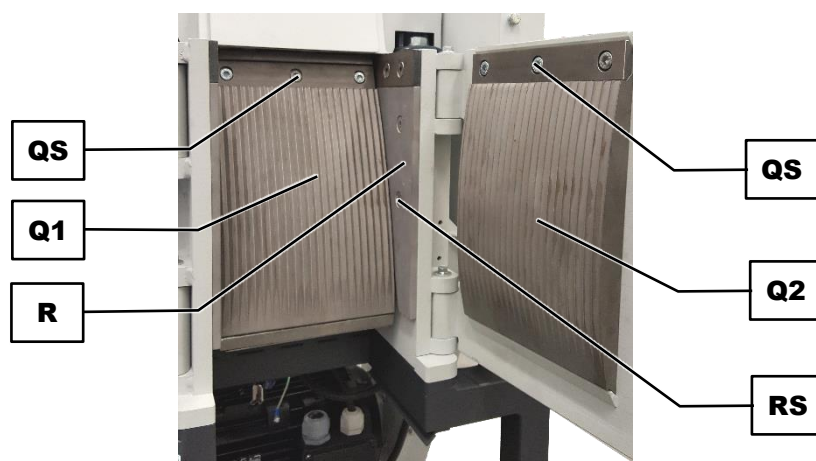

**Fig. 20:** Replacing the jaws

- ⇒ Switch the BB 400 off.
- ⇒ Disconnect the BB 400 from the power supply and secure to prevent it restarting.
- ⇒ Remove the feed hopper. .
- ⇒ Set the gap width to the maximum gap.

### Changing the jaw in the grinding chamber

- ⇒ Unscrew the M10x25 Allen screws (**QS**) of the jaw (**Q1**) in the grinding chamber.
- ⇒ Remove the clamp and then take the jaw (**Q1**) out of the grinding chamber.
- ⇒ Place the longer, new jaw (**Q1**) into the clamp of the grinding chamber with the polished side facing downwards.
- ⇒ Secure the jaw (**Q1**) using the clamp and the M10x25 Allen screws (**QS**). The tightening torque is **40 Nm**.

### Changing the jaw on the inside of the door

- ⇒ Unscrew the M10x25 Allen screws (**QS**) of the jaw (**Q**) on the inside of the door.
- ⇒ Remove the clamp and then take the jaw (**Q2**) out of the inside of the door.
- ⇒ Place the shorter, new jaw (**Q2**) into the inside of the door with the polished side facing downwards.
- ⇒ Secure the jaw (**Q2**) using the clamp and the M10x25 Allen screws (**QS**). The tightening torque is **40 Nm**.
- ⇒ Set the gap width to the necessary gap.
- ⇒ Assemble the feed hopper.

## 7.2.2 Replacing the wearing plates

### Replacing the wearing plates in the grinding chamber

Also change the wearing plates (**R**) where necessary:

- ⇒ Unscrew the M10x25 Allen flat head screws (**RS**) on the wearing plates (**R**) and remove the wearing plates (**R**) from the grinding chamber.
- ⇒ Place the new wearing plates (**R**) sideways into the grinding chamber.
- ⇒ Secure the wearing plates (**R**) using the M10x25 Allen flat head screws (**RS**) and secure the screw connection using Loctite 241.

## 7.3 Maintenance

### 7.3.1 Lubricating the device

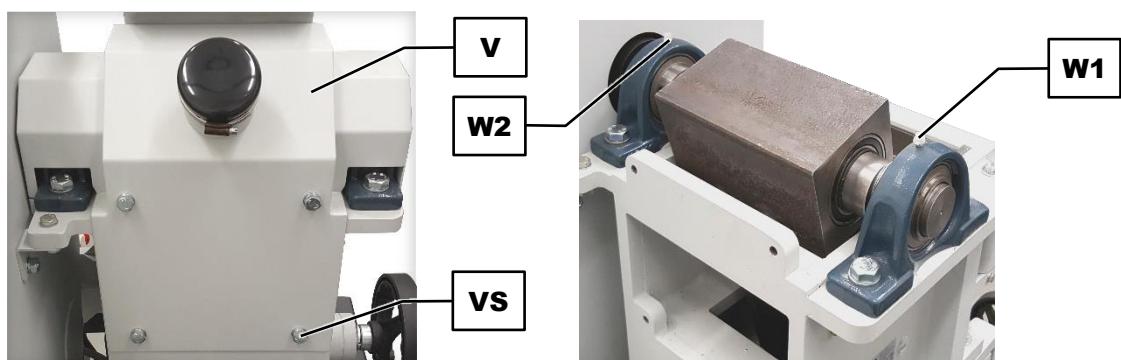

Fig. 21: Lubrication points

**NOTICE** The BB 400 must be regularly lubricated. There are two lubrication points (**W1**, **W2**) on the device. Use the supplied grease press for lubrication

The following amounts of grease are needed after specific intervals:

Lubrication point	Quantity (grams)	Interval (operating hours)	Operating state
<b>W1</b>	7	60	Standstill
<b>W2</b>	7	60	Standstill

**NOTICE** Use natural-coloured, lithium saponified (graphite-free) grease. Shell Gadus S2 V220 2 is supplied with the BB 400.

**Lubricating the lubrication points (W1, W2) under the cover**

- ⇒ Switch the BB 400 off.
- ⇒ Disconnect the BB 400 from the power supply and secure to prevent it restarting.
- ⇒ Remove the feed hopper.
- ⇒ Unscrew the four M10x25 hex screws (**VS**) on the cover (**V**) at the back of the device.
- ⇒ Remove the cover (**V**) from the device.
- ⇒ Place the grease press on the lubrication points in turn (**W1, W2**) and press the right amount of grease into the respective lubrication point.
- ⇒ Place the cover (**V**) back onto the device.
- ⇒ Secure the cover (**V**) using the four M10x25 hex screws (**VS**).
- ⇒ Assemble the feed hopper on the device.

**7.3.2 Checking the limit switch**

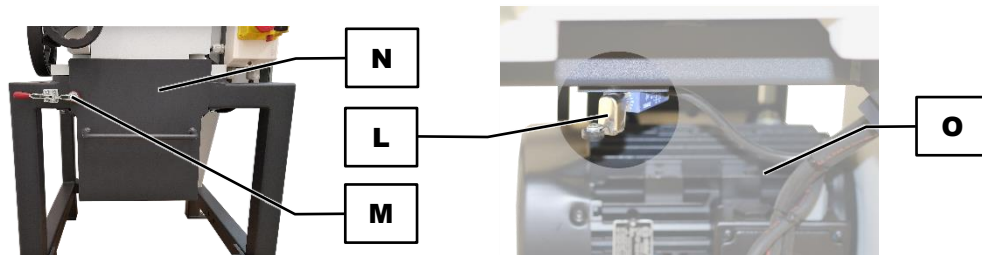

Fig. 22: Checking the limit switch

**NOTICE** The function of the limit switch (**L**) must be checked regularly every **6 months**.

**Conducting the limit switch check**

- ⇒ Switch the BB 400 on (idling).
- ⇒ Open the lock (**M**) on the collecting receptacle (**N**).
- ⇒ Pull the collecting receptacle (**N**) out.

Result: the limit switch (**L**) **must** turn the drive motor (**O**) **off**.

- ⇒ Slide the collecting receptacle (**N**) back into the base frame.

Result: the drive motor (**O**) **does not start**. It can only be switched back on using the ON switch.

- ⇒ Close the lock (**M**) on the collecting receptacle (**N**).
- ⇒ Switch the BB 400 on using the ON switch.

## 7.4 Return for Service and Maintenance



**Fig. 23:** Return form

The acceptance of devices and accessories of the Retsch GmbH for repair, maintenance or calibration can only be effected, if the return form including the decontamination declaration service has been correctly and fully completed.

- ⇒ Download the return form located in the download section "Miscellaneous" on the Retsch GmbH homepage (<http://www.retsch.com/downloads/miscellaneous/>).
- ⇒ When returning a device, attach the return form to the outside of the packaging.

In order to eliminate any health risk to the service technicians, Retsch GmbH reserves the right to refuse the acceptance and to return the respective delivery at the expense of the sender.

## 8 Accessories

Information on available accessories as well as the respective manuals are accessible directly on the Retsch GmbH homepage (<http://www.retsch.com>) under the heading "Downloads" of the device.

Information on wear parts and small accessories can be found in the Retsch GmbH general catalogue also available on the homepage.

In case of any questions concerning spare parts please contact the Retsch GmbH representative in your country, or Retsch GmbH directly.

## 9 Disposal

In the case of a disposal, the respective statutory requirements must be observed. In the following, information on the disposal of electrical and electronic devices in the European Community are given.

Within the European Community the disposal of electrically operated devices is regulated by national provisions that are based on the EU Directive 2012/19/EU on Waste Electrical and Electronic Equipment (WEEE).

Accordingly, all devices supplied after August 13<sup>th</sup> 2005 in the business-to-business area, to which this product is classified, may no longer be disposed of with municipal or household waste. To document this, the devices are provided with the disposal label.

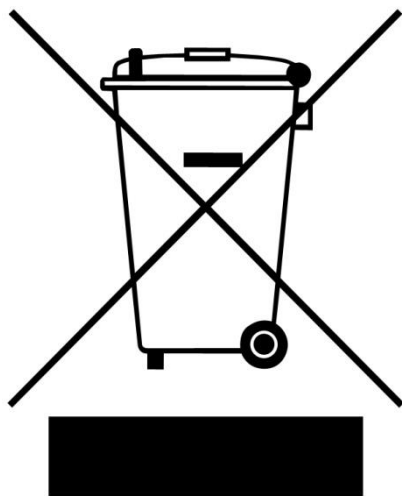

**Fig. 24:** Disposal label

Since the disposal regulations worldwide and also within the EU may differ from country to country, the supplier of the device should be consulted directly in case of need.

This labelling obligation is applied in Germany since March 23<sup>rd</sup> 2006. From this date on, the manufacturer must provide an adequate possibility of returning all devices delivered since August 13<sup>th</sup> 2005. For all devices delivered before August 13<sup>th</sup> 2005 the end user is responsible for the proper disposal.

## 10 Index

<b>A</b>	
Accessories .....	42
Ambient temperature .....	17, 18
Amendment status .....	6
Amperage .....	20
Assembly personnel .....	10
<b>B</b>	
Bar code .....	20
Base frame .....	27
Burns .....	34
<b>C</b>	
Calibration .....	41
Capacity .....	20
CE marking .....	20
Circuit breaker .....	19
Clamp	
jaw .....	39
Cleaning .....	36
compressed air .....	38
household detergent .....	38
Collecting receptacle .....	29
Collecting receptacle .....	27
Collecting receptacle .....	34
Complaints .....	16
Condensation .....	17
Confirmation form for the managing operator .....	11
Copyright .....	6
Crushing process	
starting .....	33
stopping .....	35
<b>D</b>	
Damage to hearing .....	13, 33
Degree of hardness of the sample material .....	14
Degree of protection .....	12
Device	
close .....	32
open .....	32
Device designation .....	20
Device feet .....	22
Dimensions	
Height .....	13
Dimensions .....	13
Dimensions	
Depth .....	13
Dimensions Width .....	13
direction arrow .....	19
Disclaimer .....	6
Disconnection from the mains .....	21
Disposal .....	43
label .....	43
regulations .....	43
Disposal label .....	20
Door .....	27
closing .....	33
opening .....	32
Door clamps .....	33
Door lock .....	27, 29, 33
Drive motor .....	29
Dust extraction	
cover .....	29
Dust extraction .....	22
hose clamp .....	29
socket .....	22
Dust extraction .....	29
<b>E</b>	
Electrical connection .....	18, 19
Electromagnetic compatibility .....	13
EMC .....	13
Emergency stop .....	27
Emergency stop switch .....	30, 35
Emissions .....	12
End fineness .....	25
Equivalent continuous sound level .....	12
Explanations of the safety instructions .....	7
External fuse .....	19
<b>F</b>	
Feed grain size .....	14
Feed hopper .....	38
Feed hopper .....	27, 29
assembling .....	37
cleaning .....	37
installing .....	37
removing .....	37
First commissioning .....	21
Floorspace	
Depth .....	13
Floorspace	
Width .....	13
Frequency .....	19
Front .....	26
Front view .....	26
Fuse strength .....	20
Fuse type .....	20
<b>G</b>	
Gap width	
adjusting .....	30, 31
maximum .....	32
setting .....	31
Gap width .....	12
Gap width adjustment .....	29
Gap width clamp .....	27, 29
General catalogue .....	42
General safety instructions .....	8
Grease .....	23, 40
Grease press .....	23, 39
Grinding chamber	

jaw .....	39	Operation .....	33
Grinding chamber volume.....	14	<b>P</b>	
Grinding materials.....	25	Packaging .....	16
Grinding noises .....	13	Part number .....	20
<b>H</b>		Personnel qualification and target group of this	
Humidity .....	18	manual.....	10
<b>I</b>		Pointer.....	29
Inside of the door		Power version .....	20
jaw .....	39	Principle of operation .....	25
Installation.....	16	Protective device.....	32
Installation drawing .....	15	Protective equipment .....	12
Installation drawing .....	15	Putting into service for the first time.....	23
Installation height.....	17	Putting into service for the first time	
Installation of the device .....	21	lubricating .....	23
Installation site		<b>R</b>	
conditions .....	17	Range of application of the device.....	25
<b>J</b>		Rated power.....	13
Jaws		Relative humidity	
replacing.....	38	maximum.....	18
<b>L</b>		Repair .....	9, 36, 41
$L_{eq}$ .....	12	Repair instructions .....	9
Lift		Replacing the breaking jaws.....	38
with lifting gear .....	17	Replacing the wearing plates.....	39
Limit switch .....	12, 29, 32	Required floor space.....	13
checking .....	40	Responsibility of the operating company .....	10
Limit switch check.....	40	Return .....	16
Location requirements .....	13	for service and maintenance .....	41
Lock .....	27, 29	Return device.....	43
Lock nut .....	27, 29	Return form .....	41
Loctite 241 .....	39	<b>S</b>	
Long-term operation .....	25	<b>Safety Officer</b> .....	8
Lubrication points.....	23, 39	Sample material	
cover.....	29	adding.....	33
<b>M</b>		heated .....	34
Mains frequency .....	20	removing.....	34
Mains supply .....	18	Scale .....	29
Maintenance .....	11, 36, 39, 41	adjusting the gap width .....	32
lubricating.....	39	moving.....	31
Manual .....	6, 8	zero position .....	31
Manual .....	11	Serial number.....	20
Manufacturer's address .....	20	Service address .....	9
Motor protection switch.....	12	Settings .....	30
<b>N</b>		Shell Gadus .....	23
Noise level .....	13, 33	Side view.....	28
Noise levels .....	12	Signs .....	6
Notes on the manual.....	6	Small accessories .....	42
<b>O</b>		Spare parts .....	42
OFF switch.....	27, 35	Switching on / off.....	29
ON switch .....	27	Switch-on time .....	12
ON switch .....	35	Symbols .....	6
Operating company .....	10	<b>T</b>	
Operating instructions.....	11	Target group .....	8
Operating staff .....	10	Technical data.....	12
Operating the device.....	24	Temperature fluctuations .....	17
		Temperature range .....	18
		Temporary storage.....	17
		Threaded spindle .....	27, 29

Transport .....	16	Voltage .....	19
forklift.....	17	<b>W</b>	
Transport damage .....	16	Warning.....	7
Transport pallet		Information .....	8
securing.....	21	Warranty claim .....	16
Type C characteristic .....	19	Warranty claims .....	9
Type plate .....	19, 20	Wear.....	36, 38
description .....	20	Wear parts .....	42
<b>U</b>		Wearing plates .....	38
UKCA marking .....	20	replacing.....	39
Use of the device for the intended purpose.....	24	Weight .....	13, 20
<b>V</b>		Workplace-related emissions value .....	12
V-belt cover.....	27	Wrong direction of rotation motor .....	19
Vibrations .....	21	<b>Y</b>	
Views of the instrument .....	26	Year of production.....	20

# JAW CRUSHER

BB 400 | 21.002.xxxx

## EU DECLARATION OF CONFORMITY

We, represented by the undersigned, hereby declare that the above device complies with the following directives and harmonised standards:

### Machinery Directive 2006/42/EC

Applied standards, in particular:

DIN EN ISO 12100	Machine Safety - General Design Principles
DIN EN ISO 13849-1	Safety of machinery - Safety-related parts of control systems
DIN EN 60204-1	Safety of machinery – Electrical equipment of machines

### Electromagnetic compatibility 2014/30/EU (tested at 400 V, 50 Hz)

Applied standards, in particular:

EN 55011	Industrial, scientific and medical equipment - Radio-frequency disturbance characteristics - Limits and methods of measurement
DIN EN 61326-1	Electrical equipment for measurement, control and laboratory use - EMC requirements

### Restriction of hazardous substances (RoHS) 2011/65/EU

### Authorised person for compilation of the technical documentation:

Julia Kürten (Technical Documentation)

Furthermore, we declare that the relevant technical documentation for the above device has been prepared in accordance with Annex VII Part A of the Machinery Directive and we undertake to submit the documentation to the market surveillance authorities on request.

**In the event of a modification of the device not agreed on by Retsch GmbH, as well as the use of non-approved spare parts or accessories, this declaration loses its validity.**

Retsch GmbH

Haan, 09/2023



Dr. Stefan Mähler, Technical Manager





**Retsch**<sup>®</sup>

**Copyright**

© Copyright by  
Retsch GmbH  
Retsch-Allee 1-5  
42781 Haan  
Germany